

Spitfire Mk.IXc late version

eduard

BRITISH WWII FIGHTER

1/72 SCALE PLASTIC KIT

ProfiPACK
edition

#70121



INTRO

In September 1941, a hitherto unknown German radial engine fighter appeared in the west European sky. The new airplane was superior to British fighters, most distressingly to the Spitfire Mk.V. The German design was soon recognized as the Focke-Wulf Fw 190 A. The losses suffered by the RAF over western Europe rose rapidly and the crisis was serious enough that the RAF ceased the majority of daytime operations in November, 1941. The next attempt to resume these types of sorties was made in March 1942. Loss rates remained unacceptably high and the RAF was forced to stop ops once again. All this was thanks to the Focke-Wulf Fw 190 A. The first response to the new German weapon was the Spitfire Mk.VIII, but the design changes were so complex that initiating timely production was not possible. In June, 1942, a German pilot landed by mistake on a British airfield delivering a completely intact Fw 190 fighter into RAF hands. Comparative trials between the Focke-Wulf and Spitfire Mk.V began almost immediately. These mock encounters confirmed the situation over the front – the chances of a British fighter surviving an encounter with the Fw 190 were slim. The only British fighter aircraft deemed suitable to oppose them were the Spitfire Mk. VII and VIII powered by the Merlin 61 engine. As mentioned above these were some time away of being ready for series production. But there was another way of getting a powerful fighter quickly - by mating the Merlin 61, with its two-stage supercharger, with the fuselage of the Spitfire Mk.Vc. Two Mk.Vc airframes, AB196 and AB197, were selected for this purpose and were strengthened with modified longerons to accommodate the more powerful and heavier engine. The example was finished on February 26 and the second on March 27, 1942. Flight trials were successful and the order for series production was issued almost immediately. Series production began in June 1942 and the first Mk.IXs found their way to No. 64 Squadron in July. Performance improved significantly in comparison to the Mk.V. A top speed of 409 mph at 28,000 feet was higher by 40mph, and the service ceiling rose from 36,200 to 43,000 feet. The Mk.IX could climb at 4,000 feet per minute. The RAF finally had a fighter aircraft capable of opposing the Fw 190 A. Three main versions of the Mk IX were produced. The F.IX was powered by the Merlin 61 and was the only version on the assembly line in early 1943. The next version was the LF Mk.IX powered by the Merlin 66. This engine was designed to do its best at low altitudes. The third version, manufactured along with the LF, was the high-altitude HF Mk.IX with the Merlin 70. The majority of Mk.IXs manufactured were equipped with the so-called 'C' wing. Four 20mm cannon or two 20mm cannon and four .303 machine guns could be installed in the wings. From 1944, the strengthened 'E' wing was produced. Four .303 machine guns were replaced with two .50 heavy machine guns. Bomb racks for 250lb bombs were fitted under each wing typically. The Mk.IX became the second most numerous version of the Spitfire with a total of 5653 examples being built. The Mk.IX began to replace the Mk.V from June, 1942. Thanks to the new fighter, the RAF was ready to fight against the Luftwaffe over occupied Europe. Spitfire Mk.IXs served with the RAF to the end of war. In the postwar era, foreign air forces flew this version as well. Czechoslovak, Norwegian, Danish, and Canadian air forces operated numbers of Mk.IXs and they were not alone. Spitfires would find themselves in combat again. Czechoslovakia sold its Spitfire Mk.IXs to Israel in 1948 and these aircraft formed the backbone of the newly born Israeli air force in the fight against their Arab neighbours.

ATTENTION



UPOZORNĚNÍ



ACHTUNG



ATTENTION



注意



Carefully read instruction sheet before assembling. When you use glue or paint, do not use near open flame and use in well ventilated room. Keep out of reach of small children. Children must not be allowed to suck any part, or pull vinyl bag over the head.



Před započítím stavby si pečlivě prostudujte stavební návod. Při používání barev a lepidel pracujte v dobře větrané místnosti. Lepidla ani barvy nepoužívejte v blízkosti otevřeného ohně. Model není určen malým dětem, mohlo by dojít k požití drobných dílů.

INSTRUCTION SIGNS



INSTR. SYMBOLS



INSTRUKTION SINNBILDEN



SYMBOLES



記号の説明

OPTIONAL
VOLBABEND
OHNOUTOPEN HOLE
VYVRTAT OTVORSYMETRICAL ASSEMBLY
SYMETRICKÁ MONTÁŽNOTCH
ZÁŘEZREMOVE
ODŘÍZNOUTAPPLY EDUARD MASK
AND PAINT
POUŽIT EDUARDS MASK
NABARVIT

PARTS



DÍLY



TEILE



PIÈCES



部品

PLASTIC PARTS

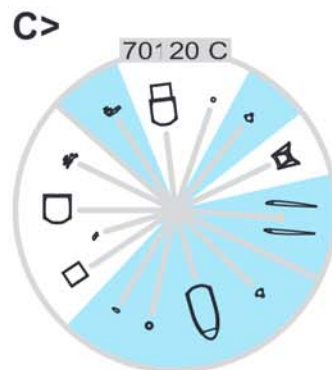
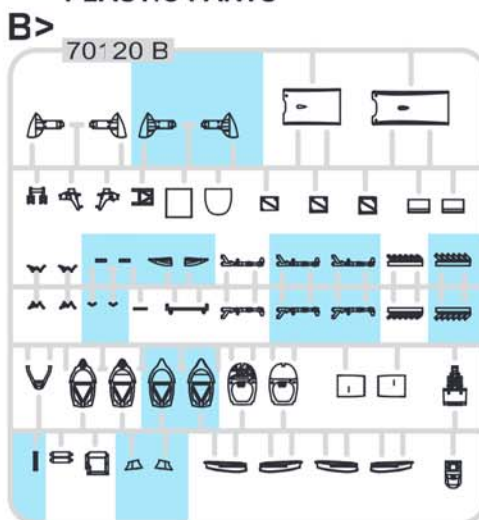
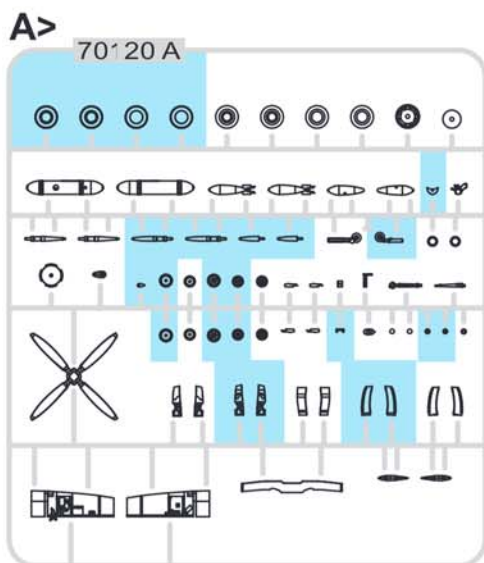

D> 70120 D

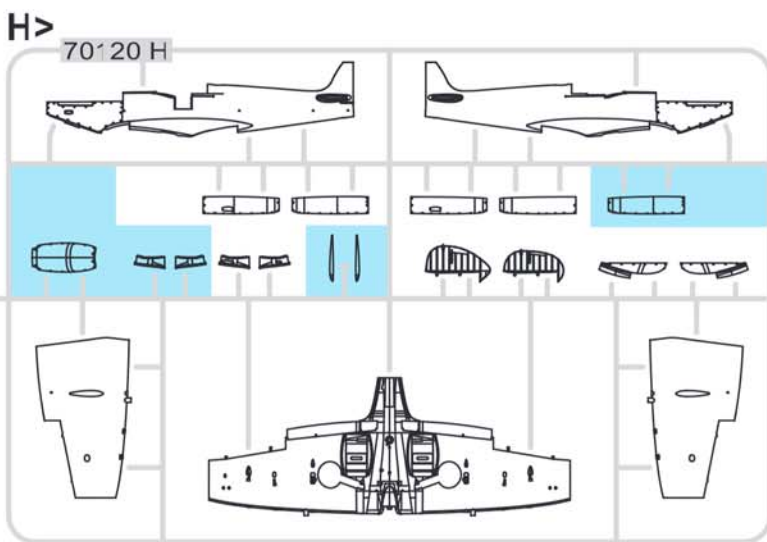

E> 70120 E

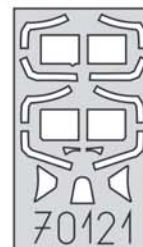
eduard
MASKPE - PHOTO ETCHED
DETAIL PARTS

-Parts not for use -Teile werden nicht verwendet -Pièces à ne pas utiliser -Tyto díly nepoužívejte při stavbě - 使用しない部品

COLOURS



BARVY



FARBEN



PEINTURE



色

| GSI Creos (GUNZE) | | |
|-------------------|----------|-----------------|
| AQUEOUS | Mr COLOR | |
| H14 | C4 | YELLOW |
| H12 | C33 | FLAT BLACK |
| H13 | C3 | FLAT RED |
| H33 | C81 | RUSSET |
| H61 | C11 | LIGHT GULL GRAY |
| H62 | C12 | OLIVE DRAB |
| H74 | C368 | SKY |
| H77 | C137 | TIRE BLACK |
| H112 | C312 | GREEN |

| AQUEOUS | Mr COLOR | |
|-------------------------|----------|-----------------|
| H316 | C316 | WHITE |
| H330 | C361 | DARK GREEN |
| H335 | C363 | MEDIUM SEA GRAY |
| | C362 | OCEAN GRAY |
| Mr.COLOR SUPER METALLIC | | |
| SM06 | | CHROME SILVER |
| Mr.METAL COLOR | | |
| MC211 | | DARK IRON |
| MC218 | | ALUMINIUM |

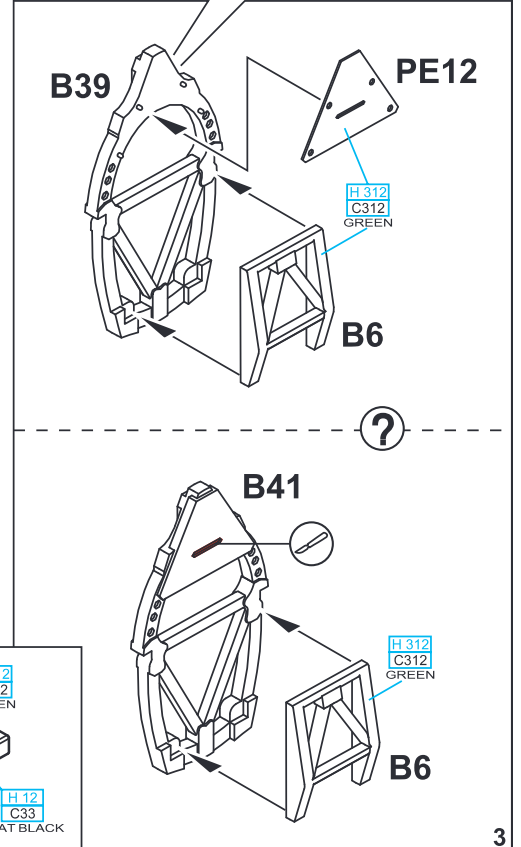
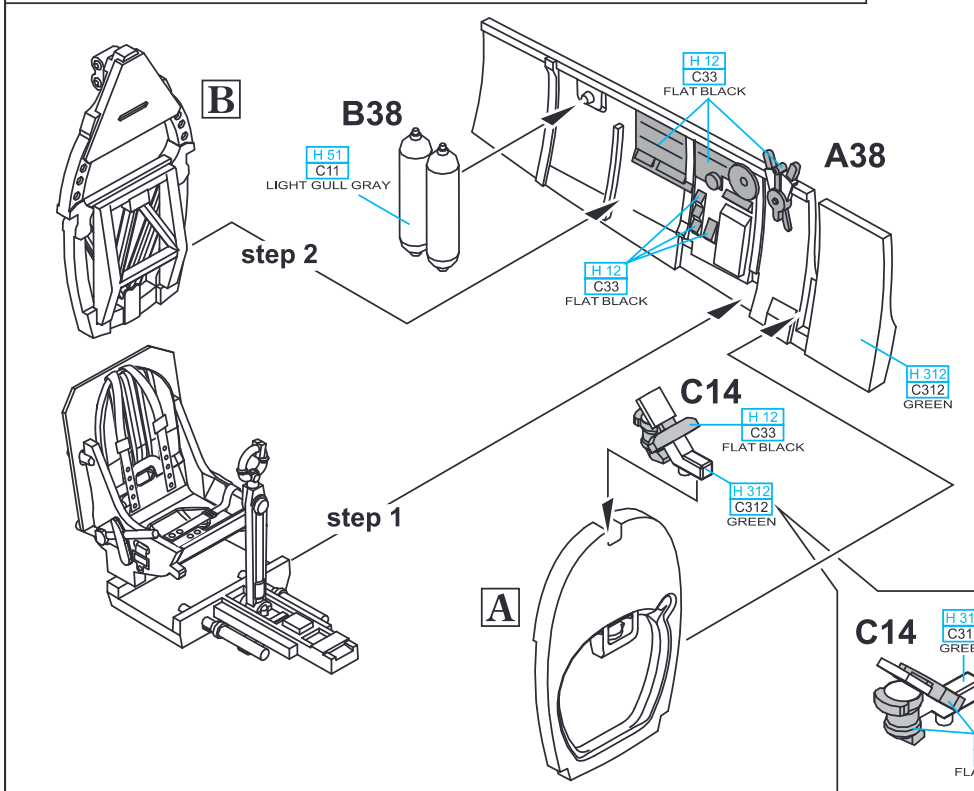
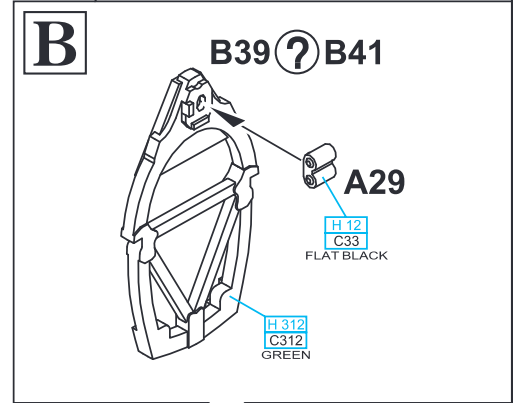
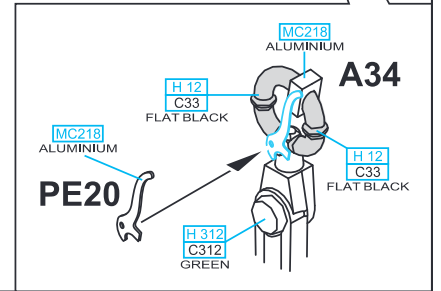
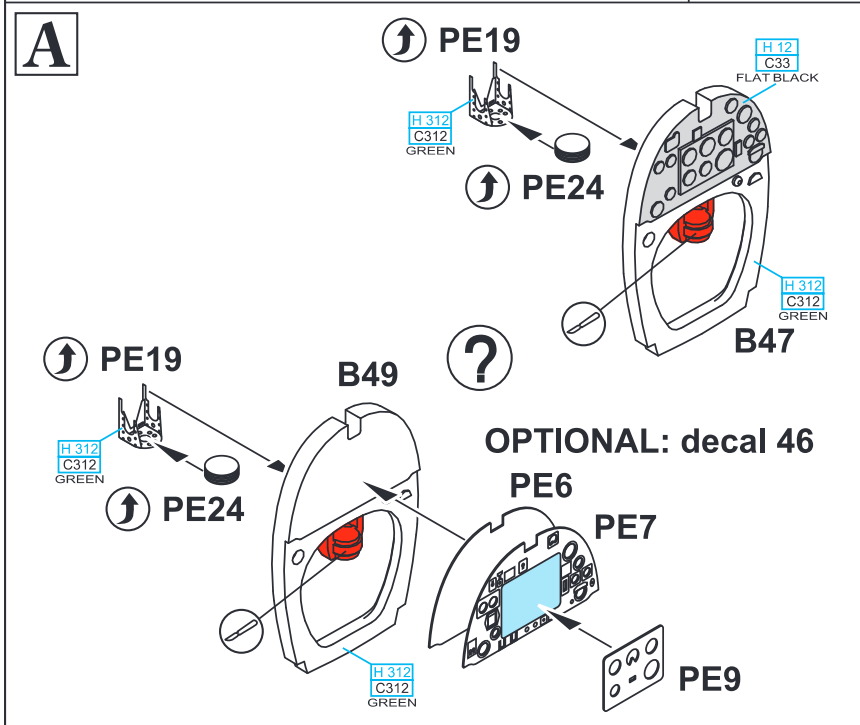
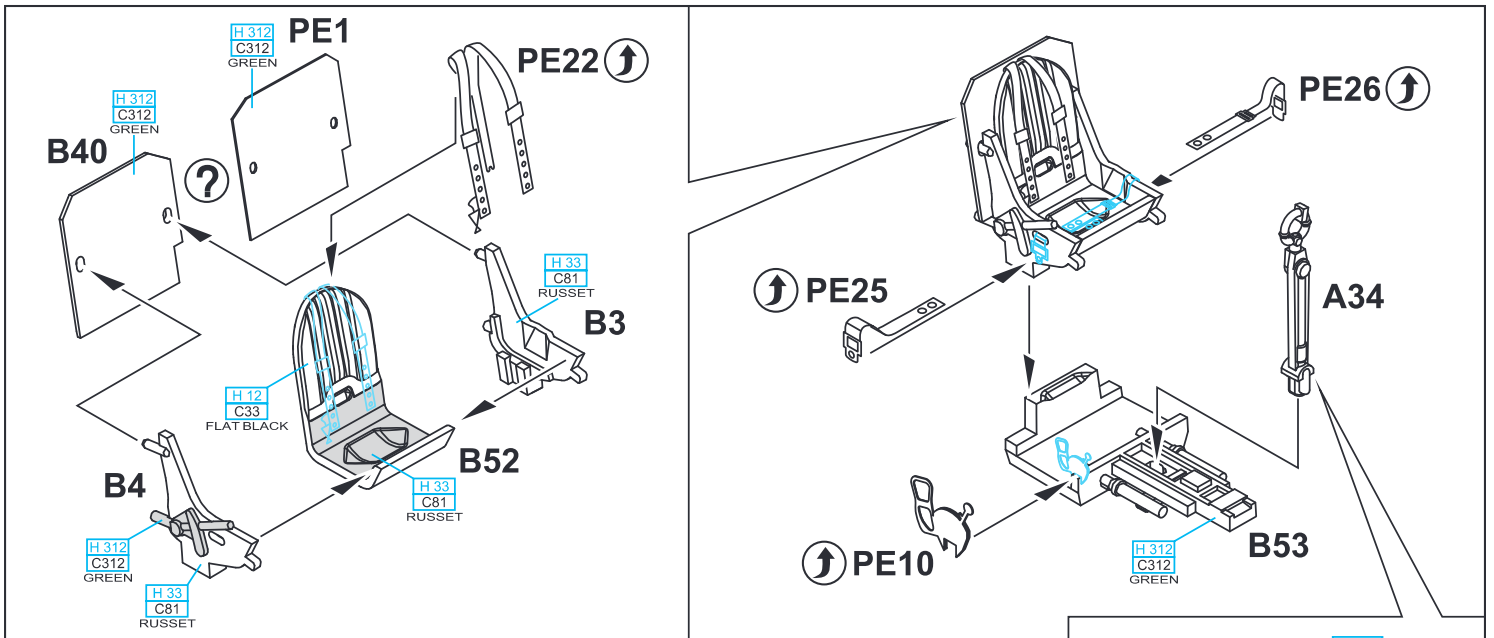

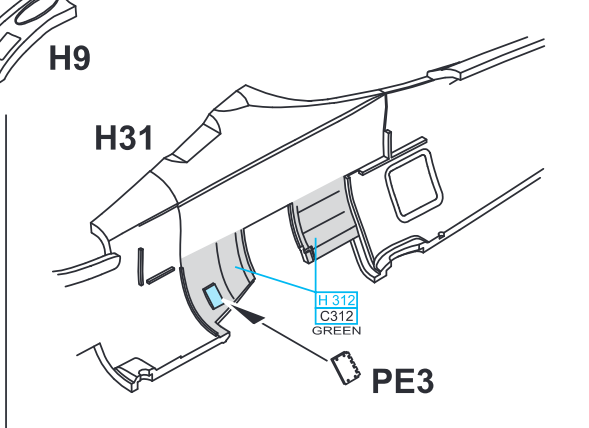
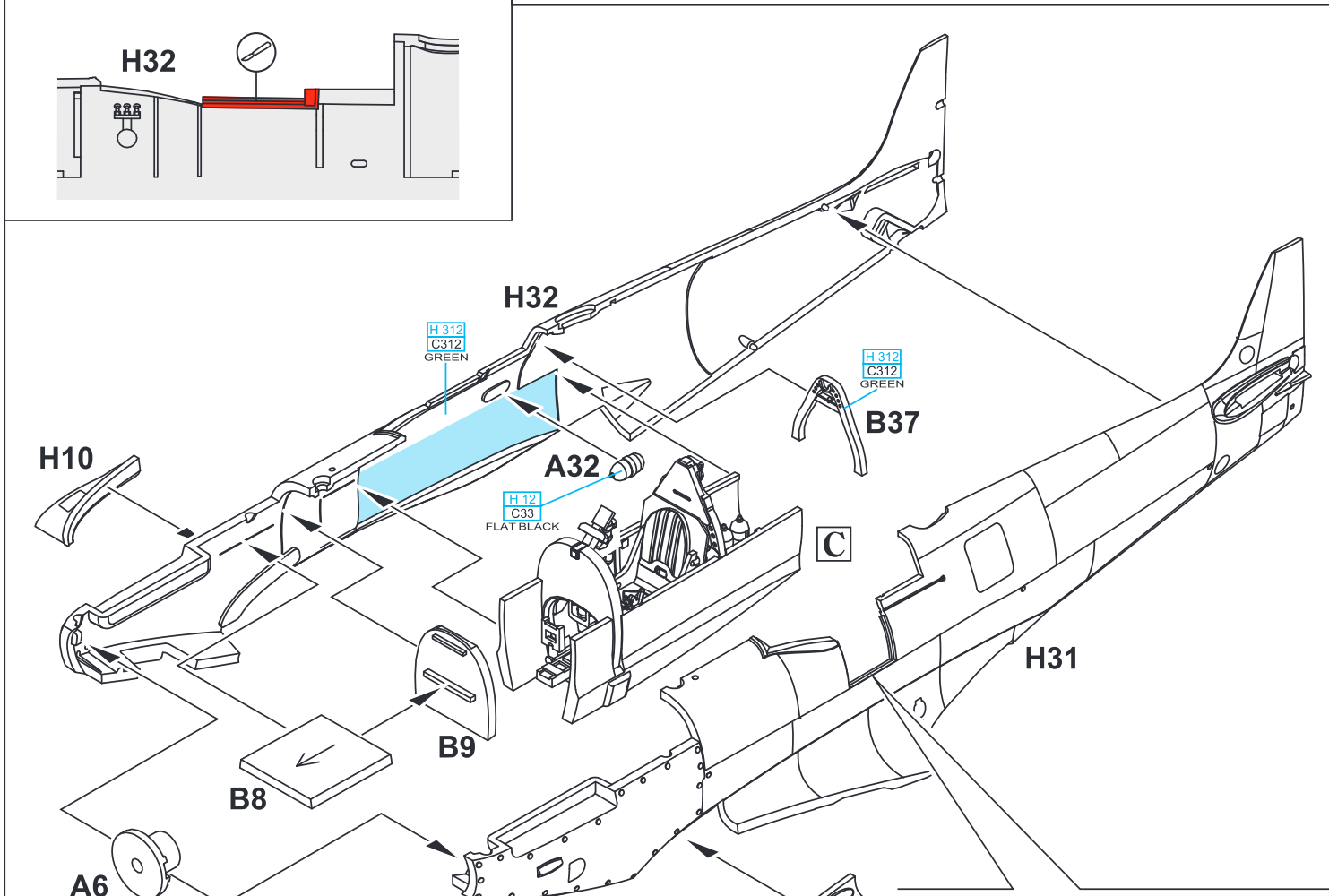
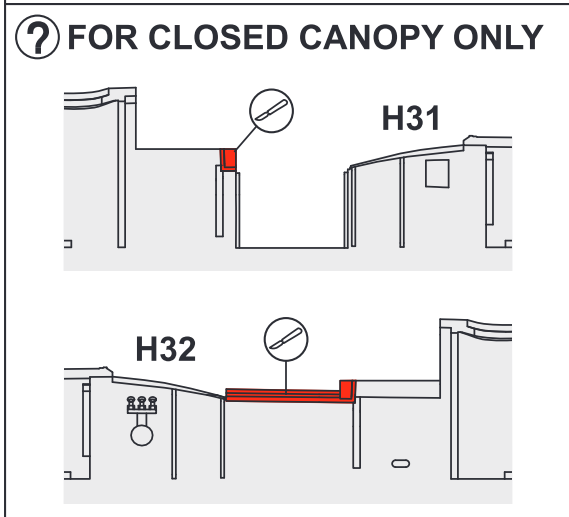
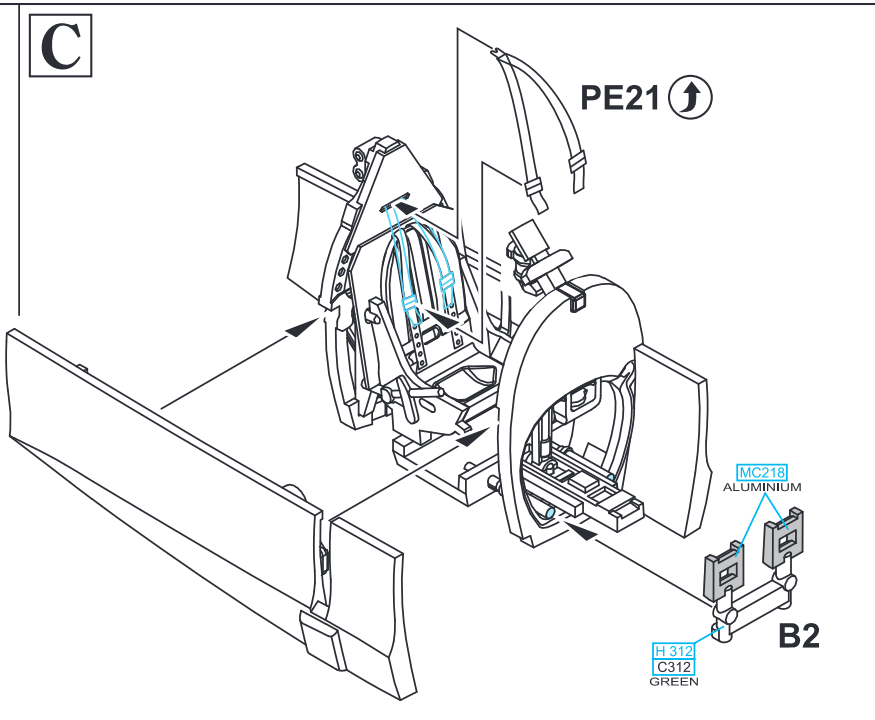
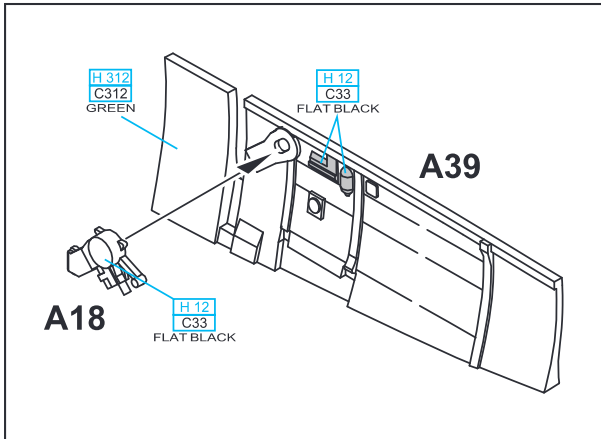

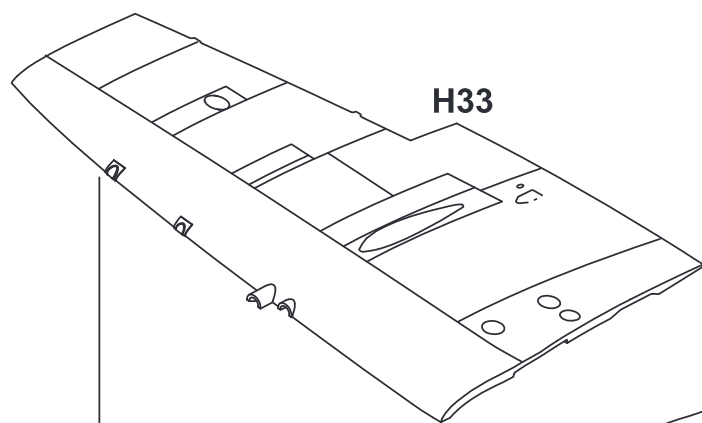
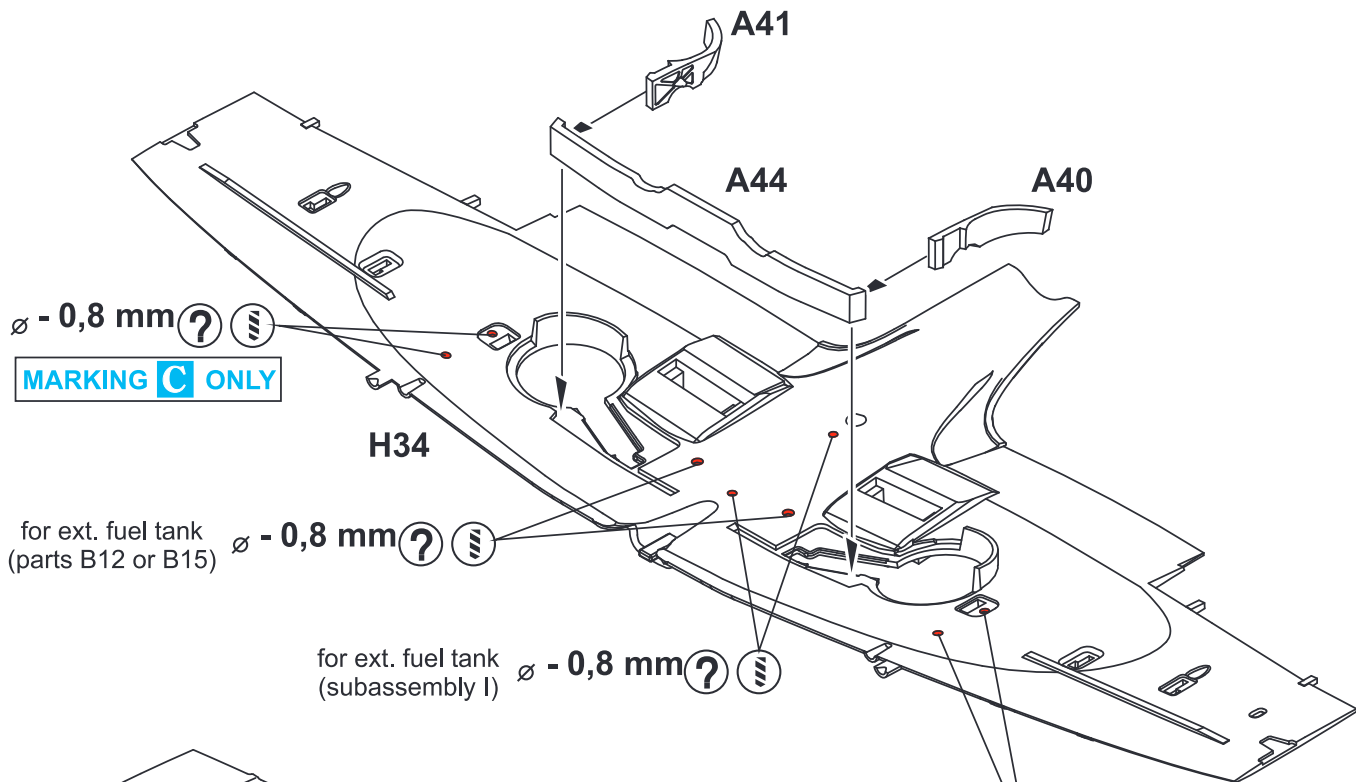

$\varnothing - 0,8 \text{ mm}$?

MARKING C ONLY

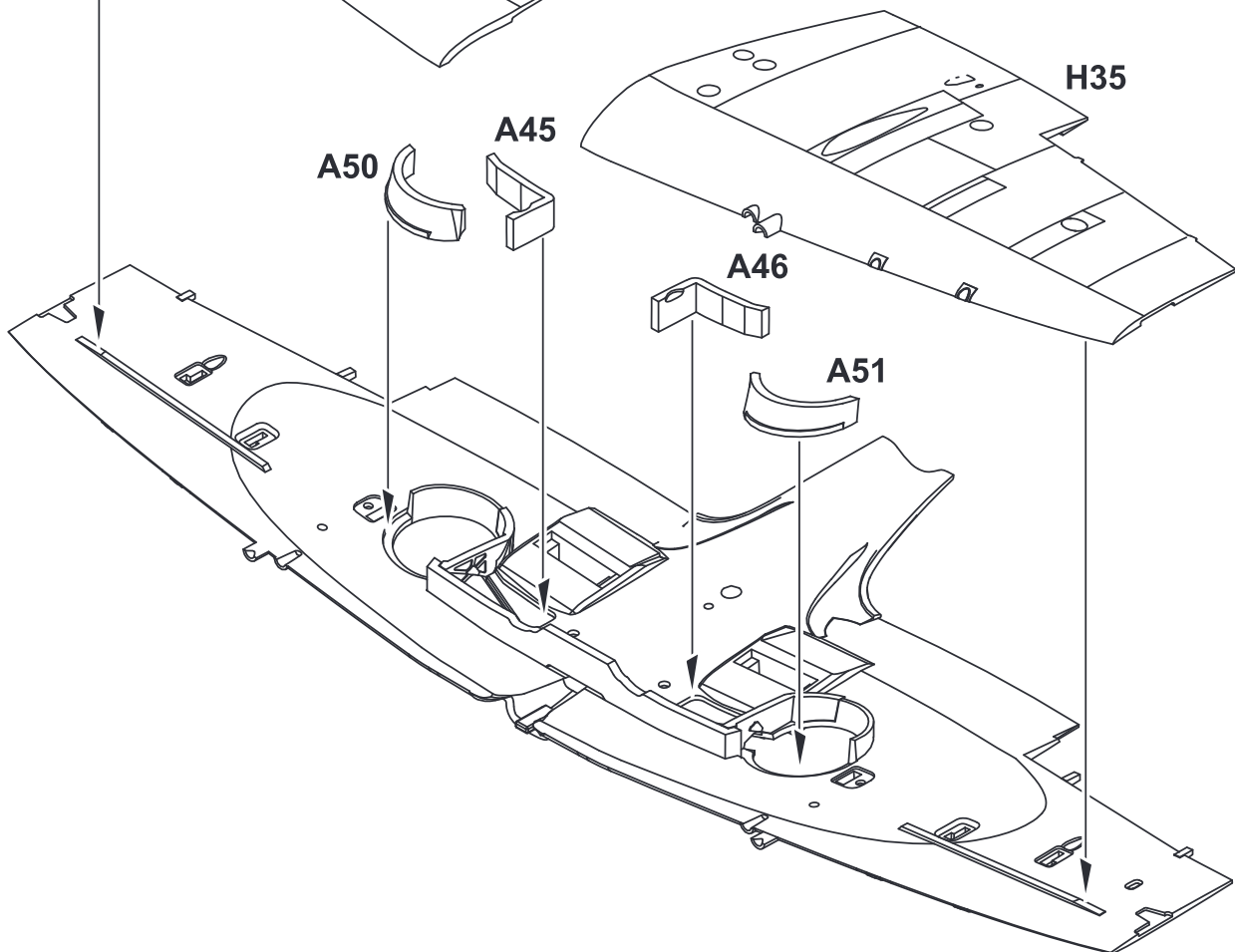

H3, H4 - MARKING **B** ONLY

H1 ? H3

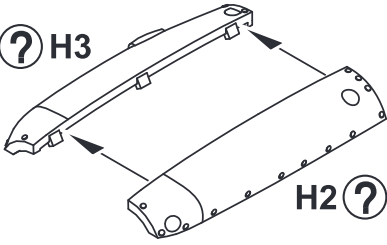

H2 ? H4

H 312
C312
GREEN

B21

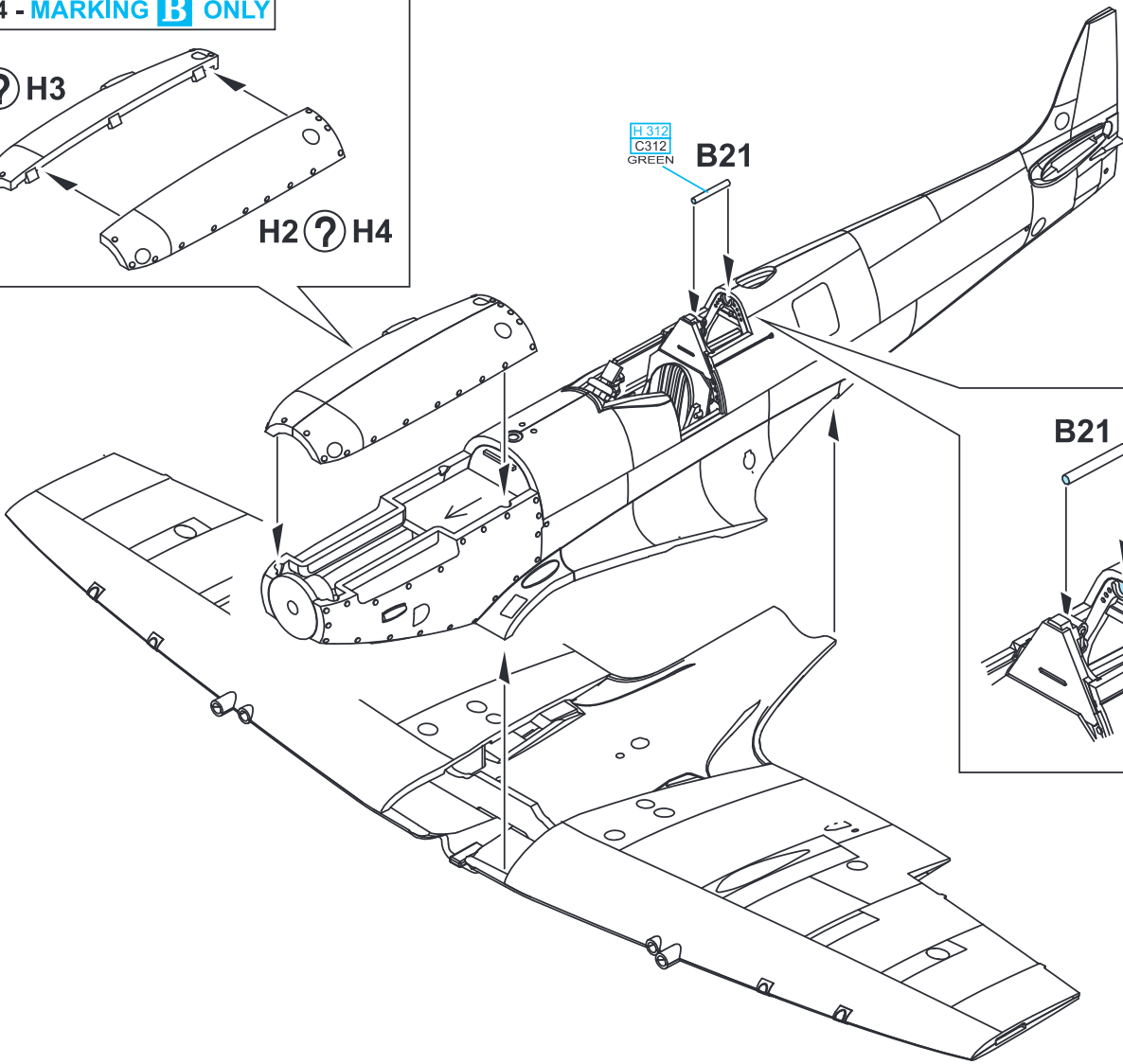

B21

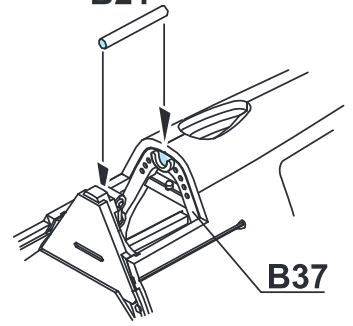

B37

D19

E29

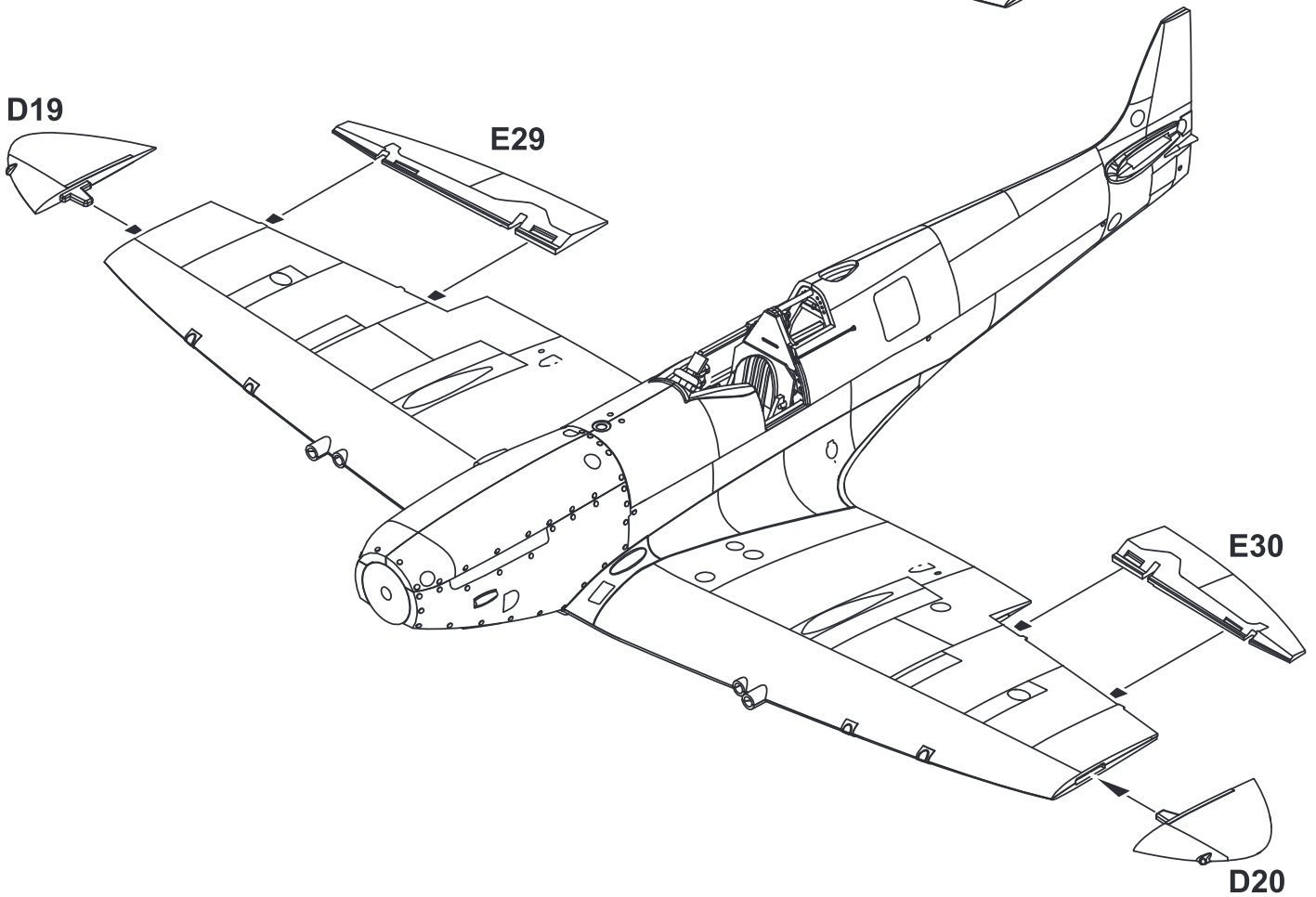

E30

D20

H13 - MARKING C ONLY

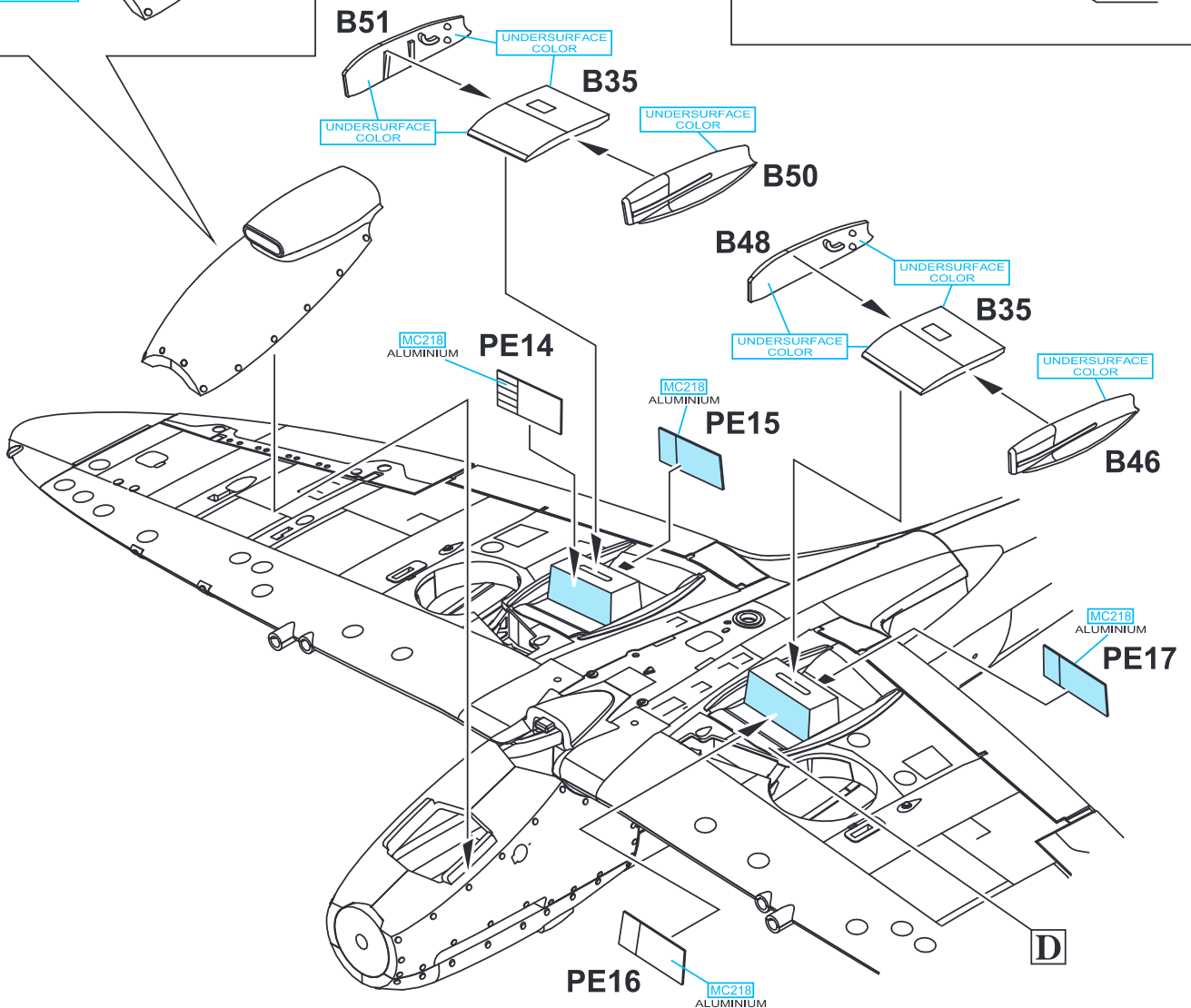
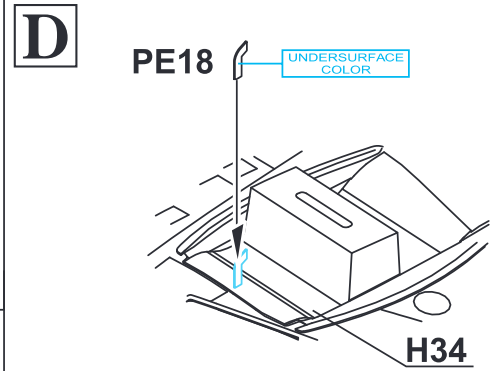
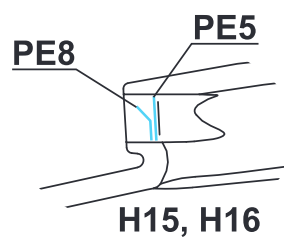
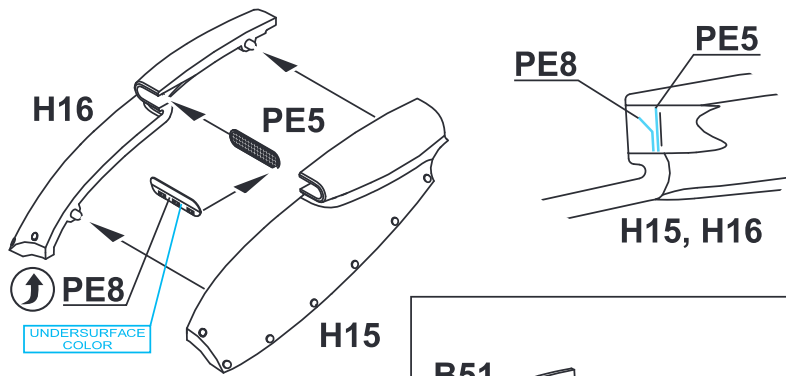
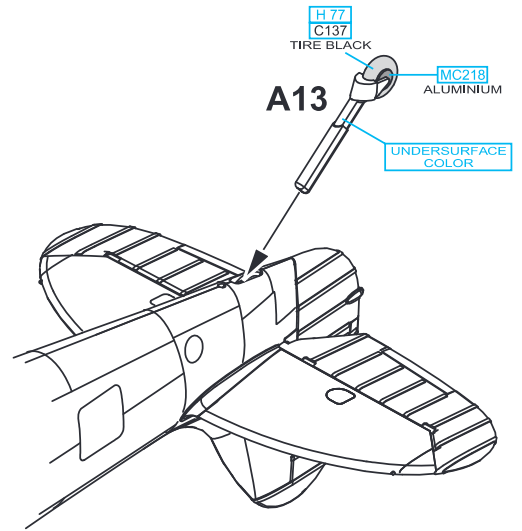
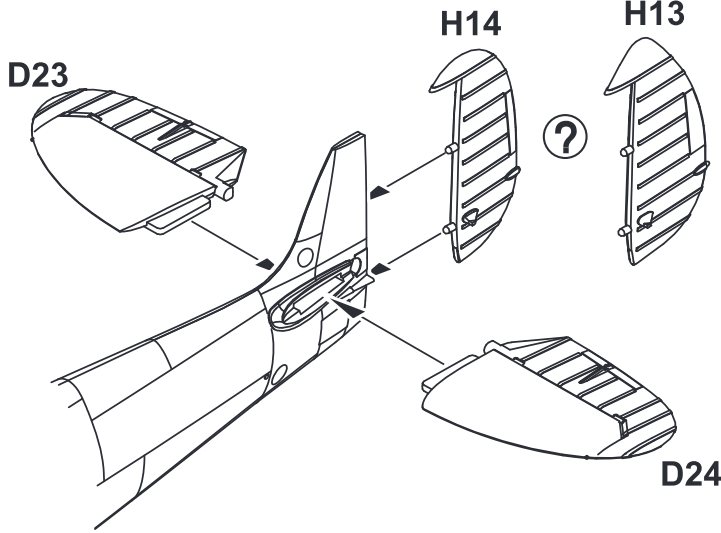

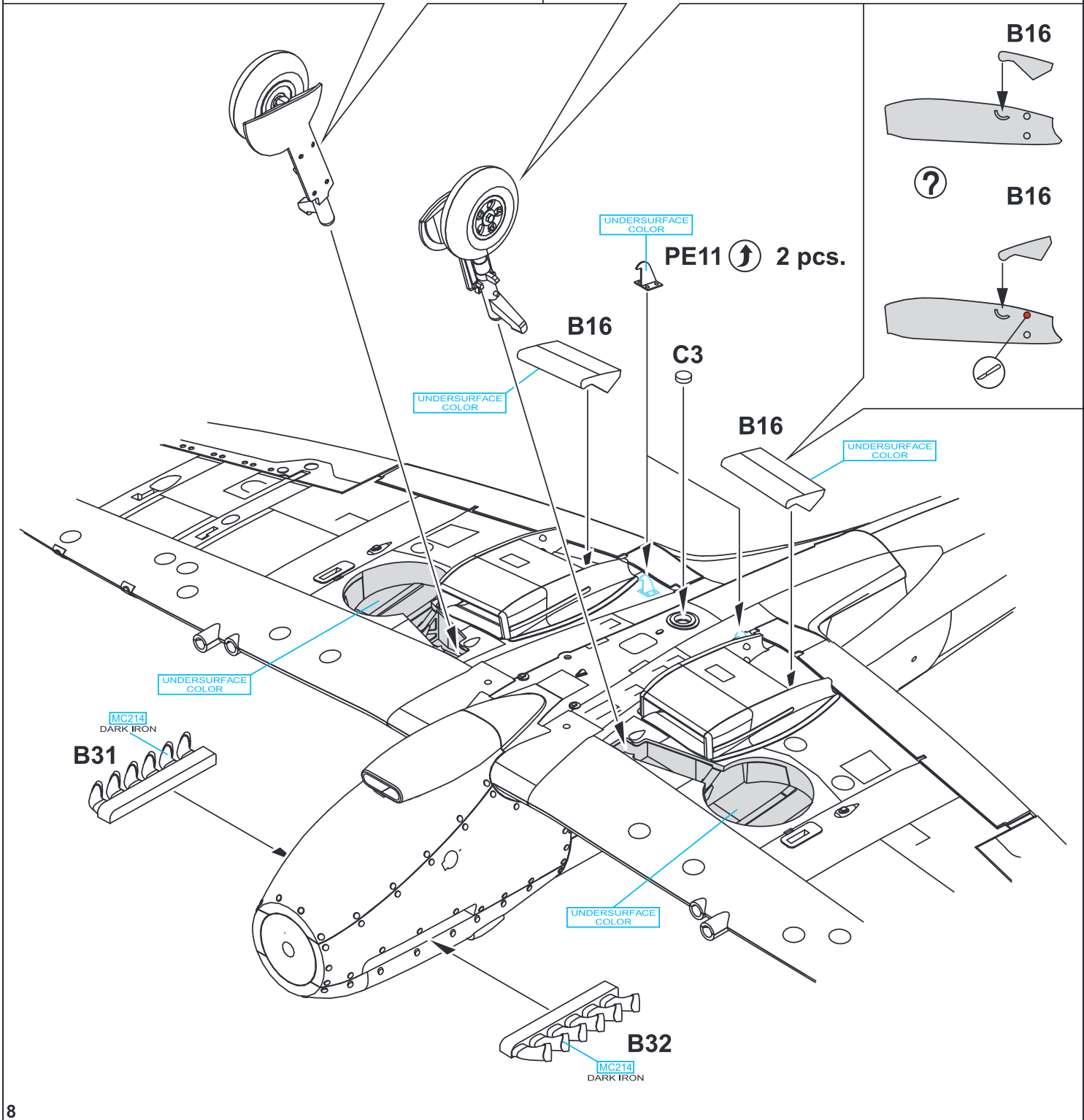
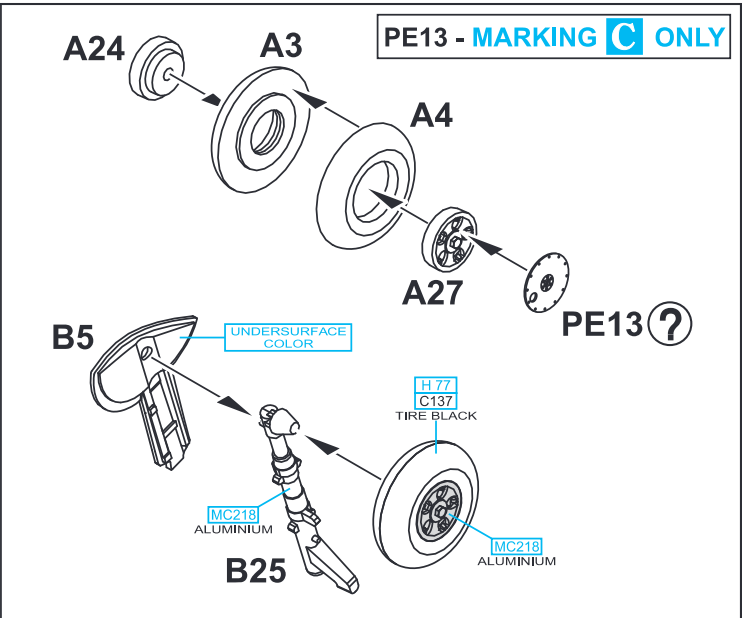
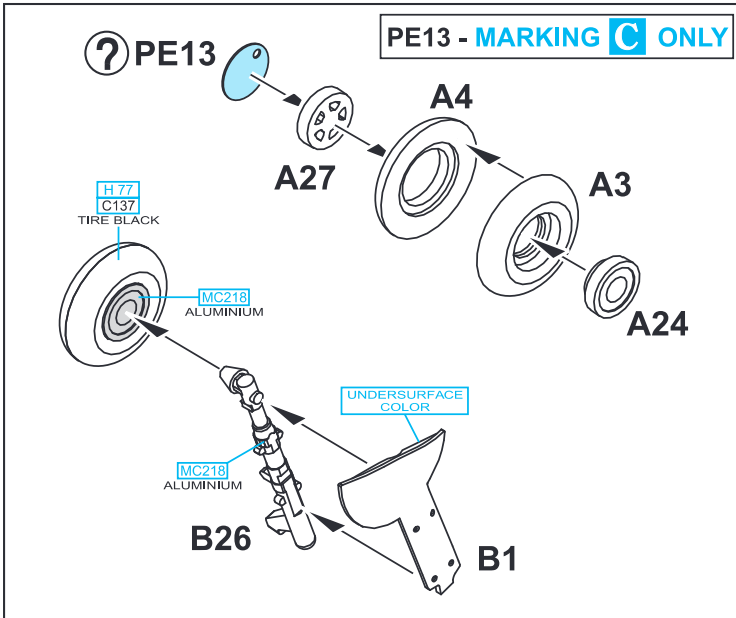

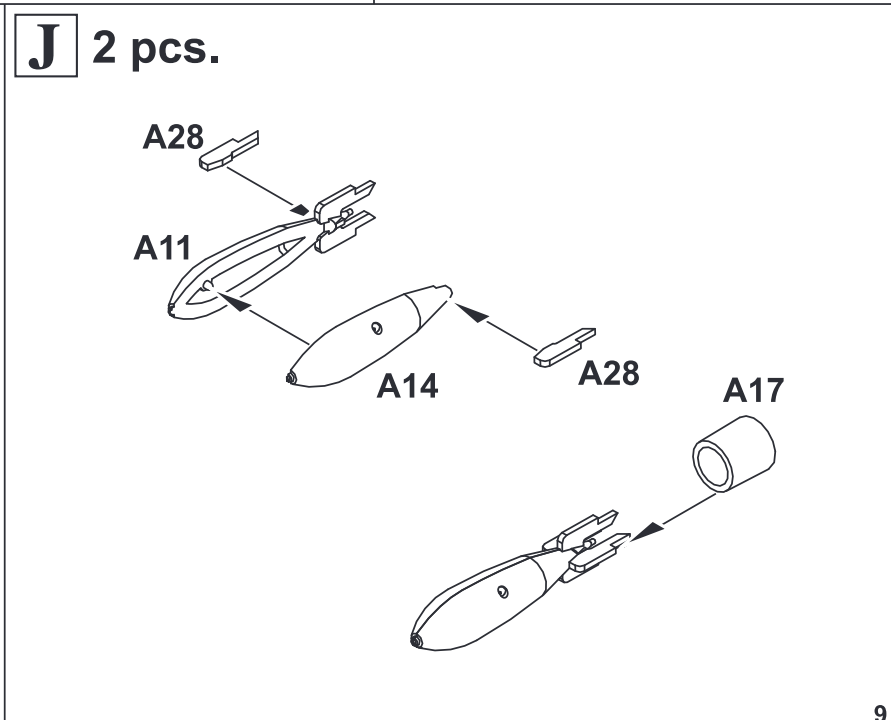
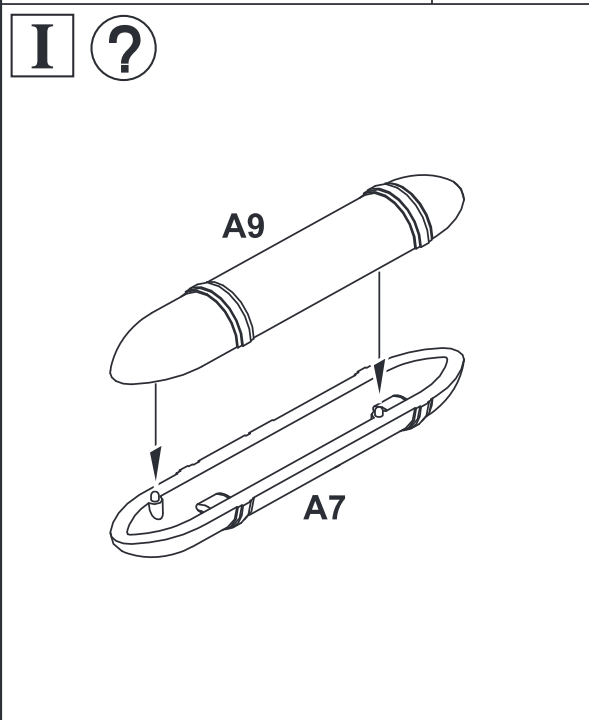
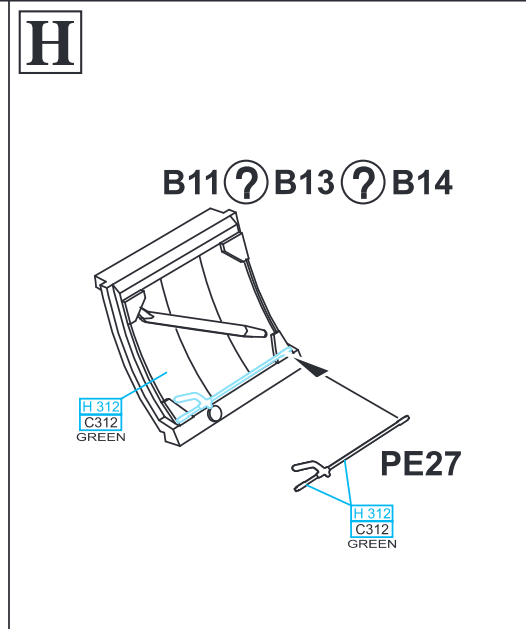
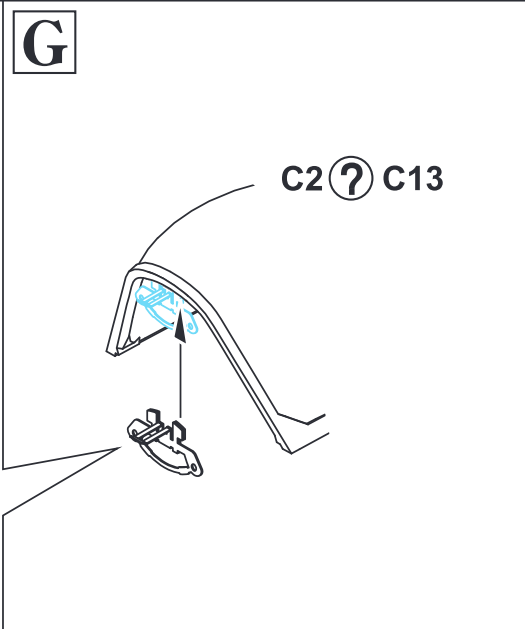
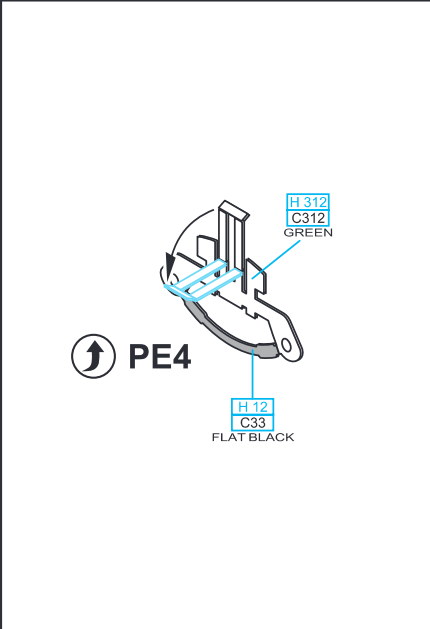
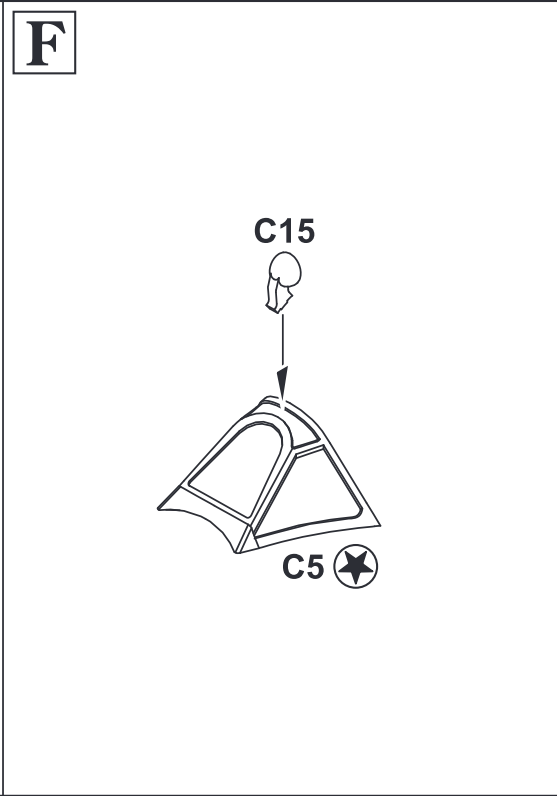
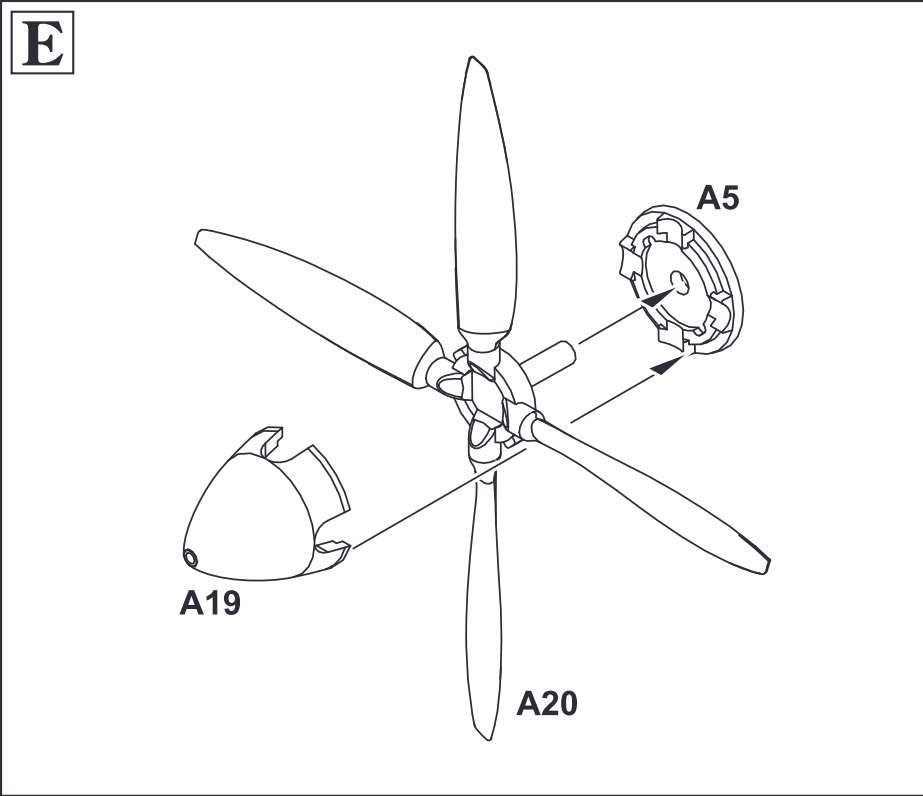

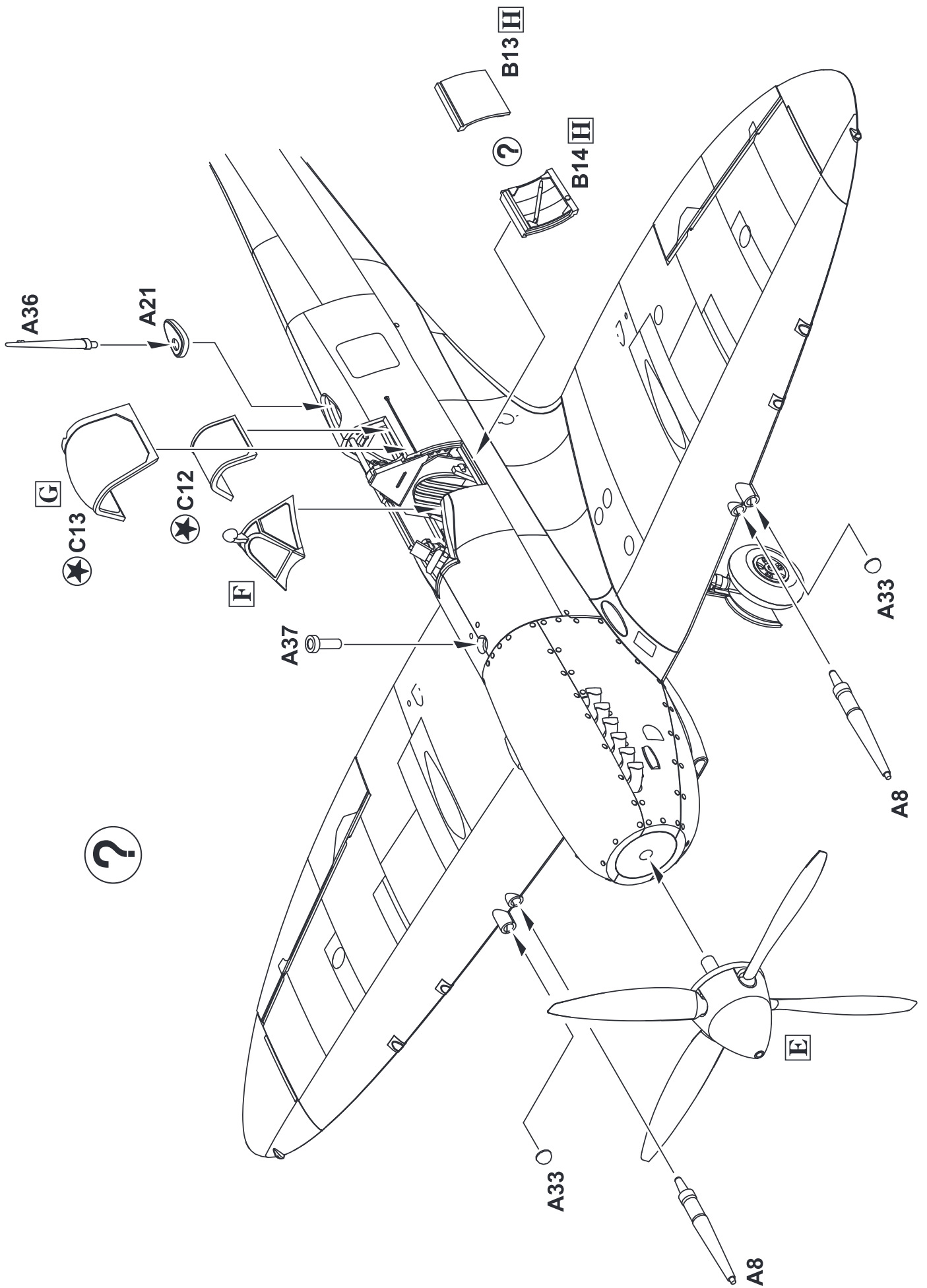

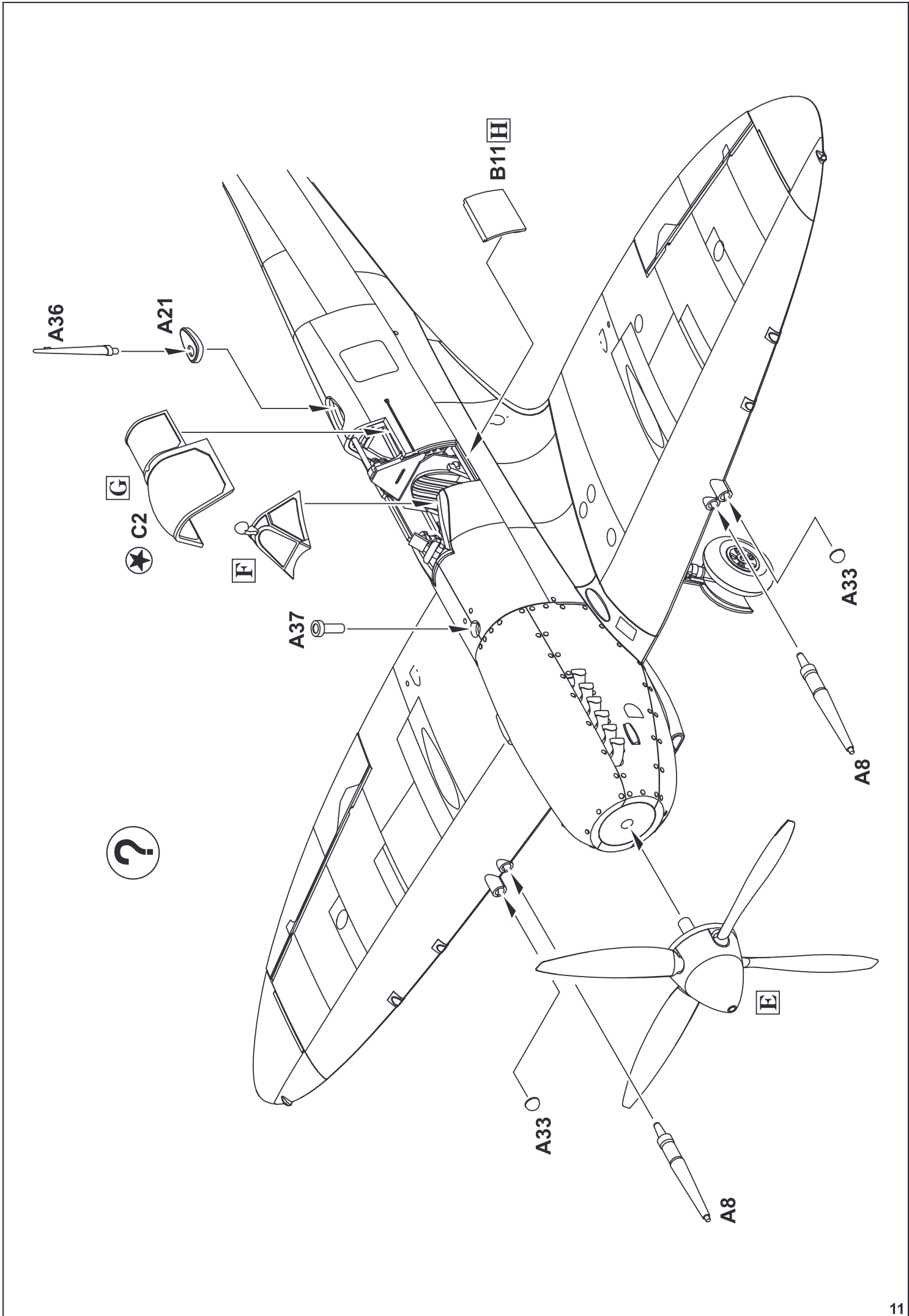

?

B12

UNDERSURFACE
COLOR

?

B15

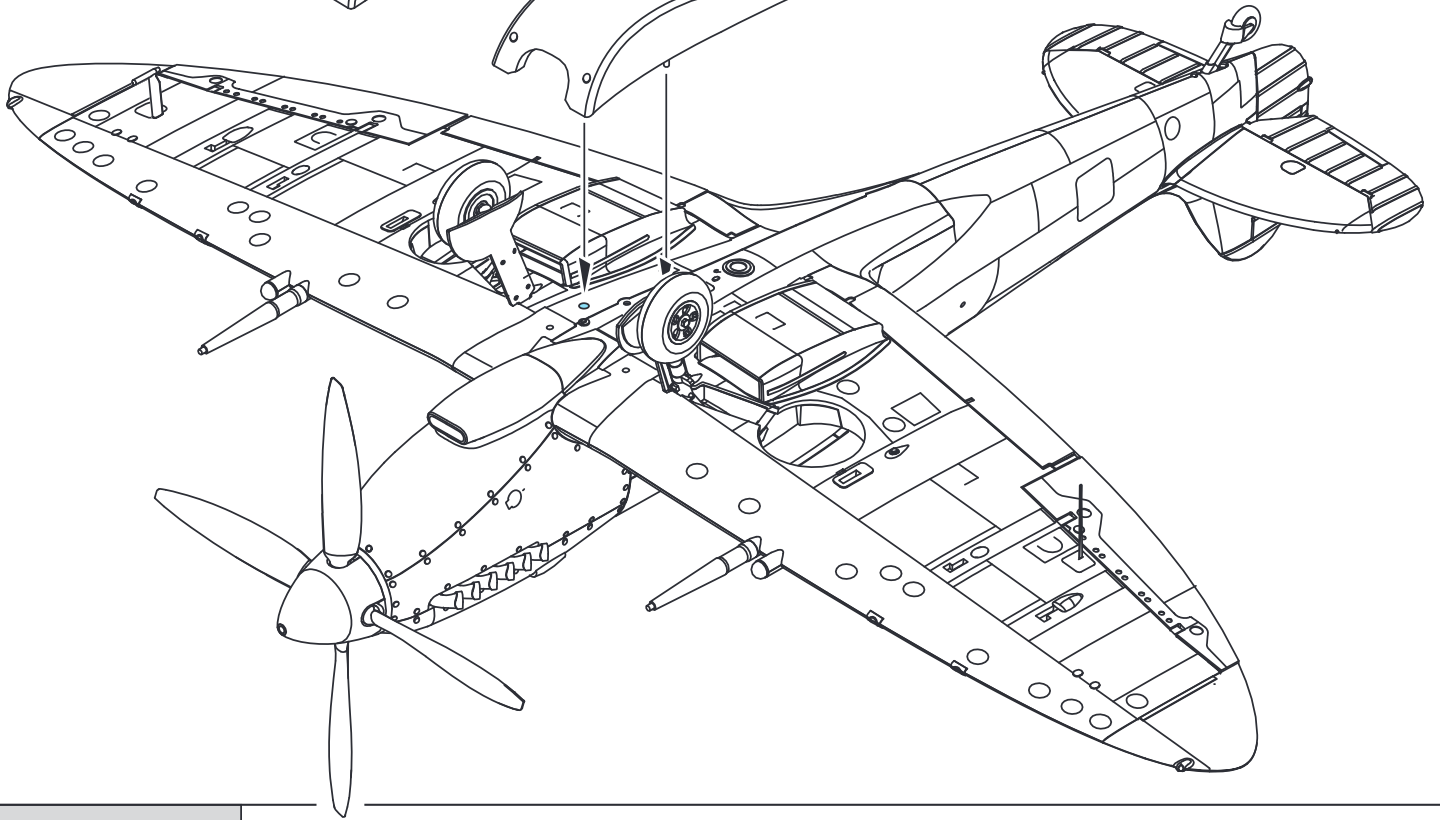

eduard
MASK

70121

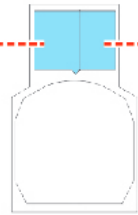
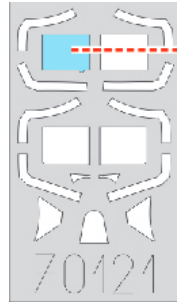
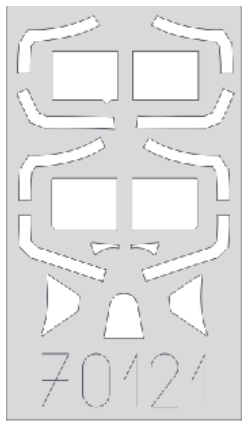

C2

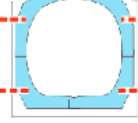
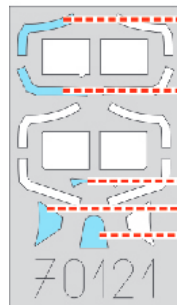

C5

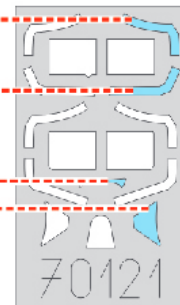

C12

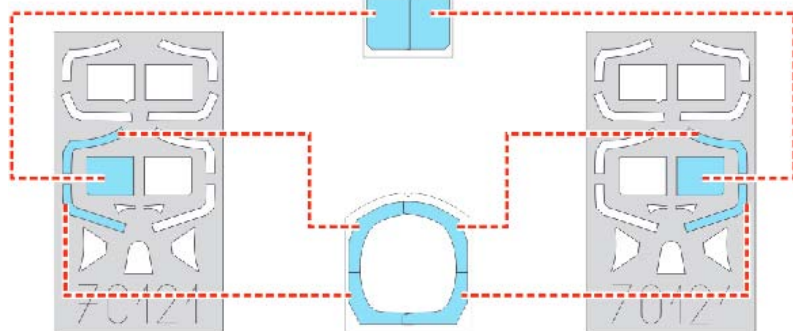

C13

A Spitfire LF Mk.IXc, MJ586, flown by Pierre Clostermann, No. 602 Squadron, Longues sur Mer airfield, July 7 1944

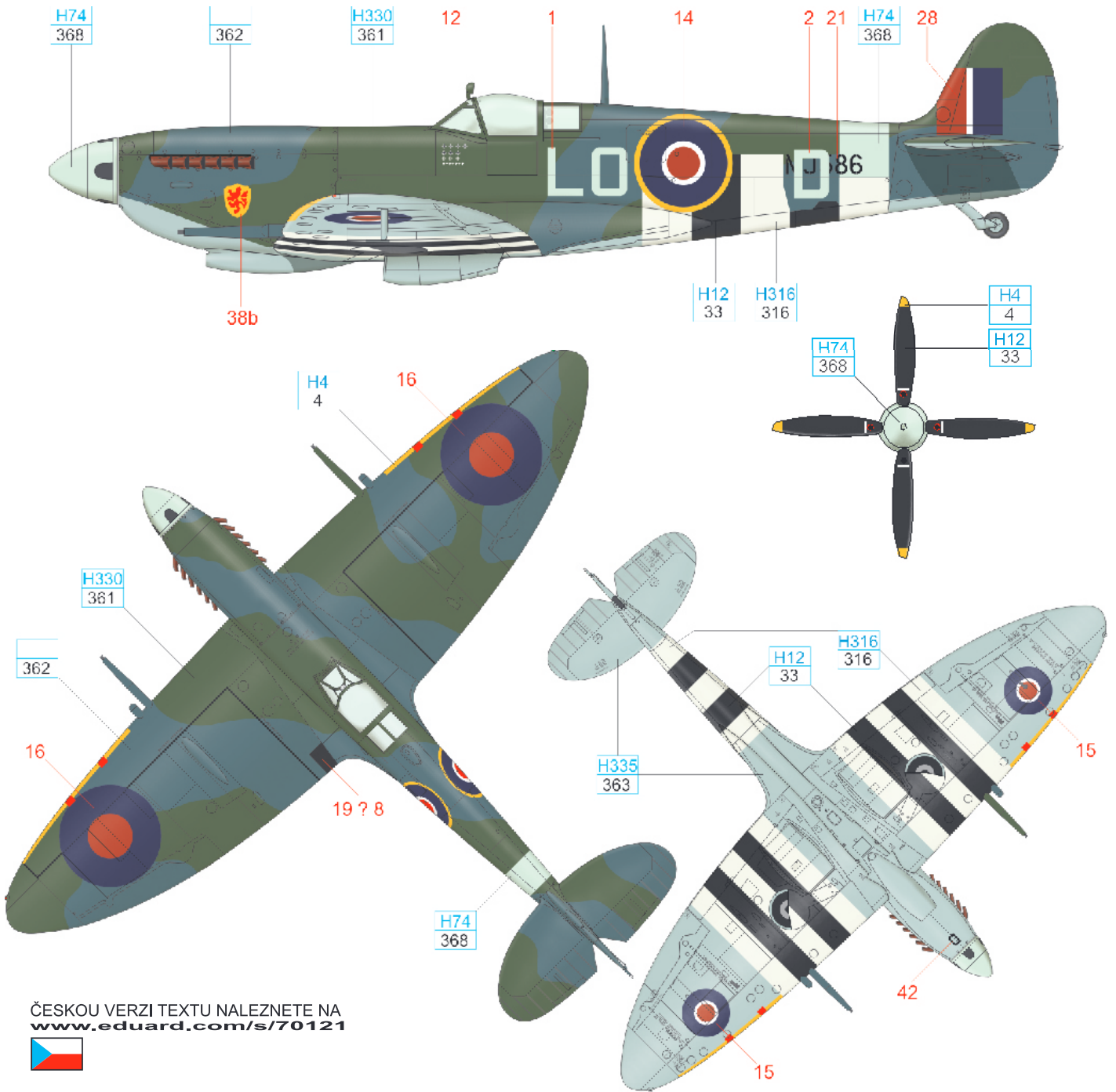

ČESKOU VERZI TEXTU NALEZNETE NA
www.eduard.com/s/70121

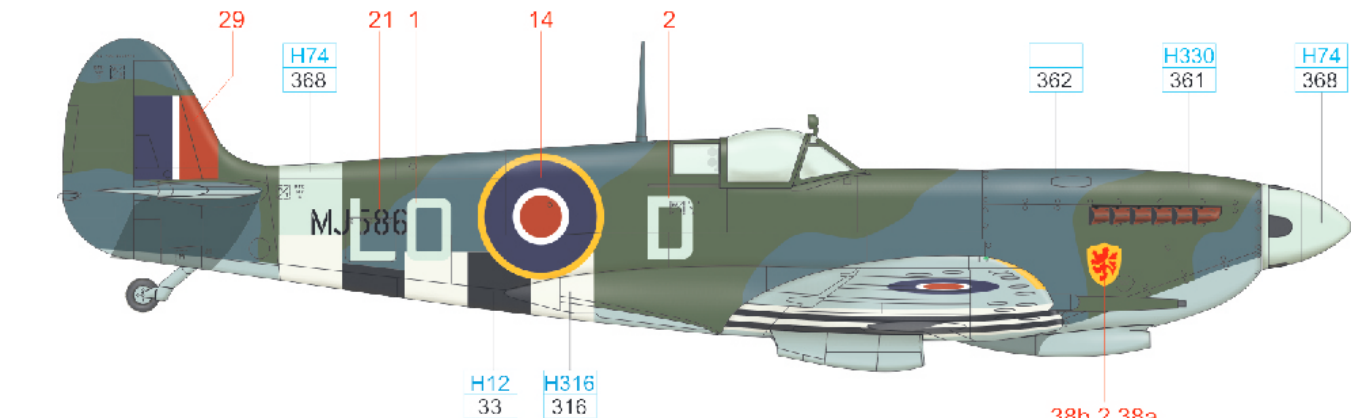

| | | | |
|-------|-------------|--------|---------|
| WHITE | H316 316 | YELLOW | H4 4 |
|-------|-------------|--------|---------|

| | | | | | | | | | |
|-----|------------|-----------------|-------------|------------|-----|------------|-------------|-------|-----------|
| SKY | H74 368 | MEDIUM SEA GRAY | H335 363 | OCEAN GRAY | 362 | DARK GREEN | H330 361 | BLACK | H12 33 |
|-----|------------|-----------------|-------------|------------|-----|------------|-------------|-------|-----------|

B Spitfire HF Mk.IXc, ML296, flown by F/Lt Otto Smik, No. 312 Squadron, North Weald AB, Late August 1944

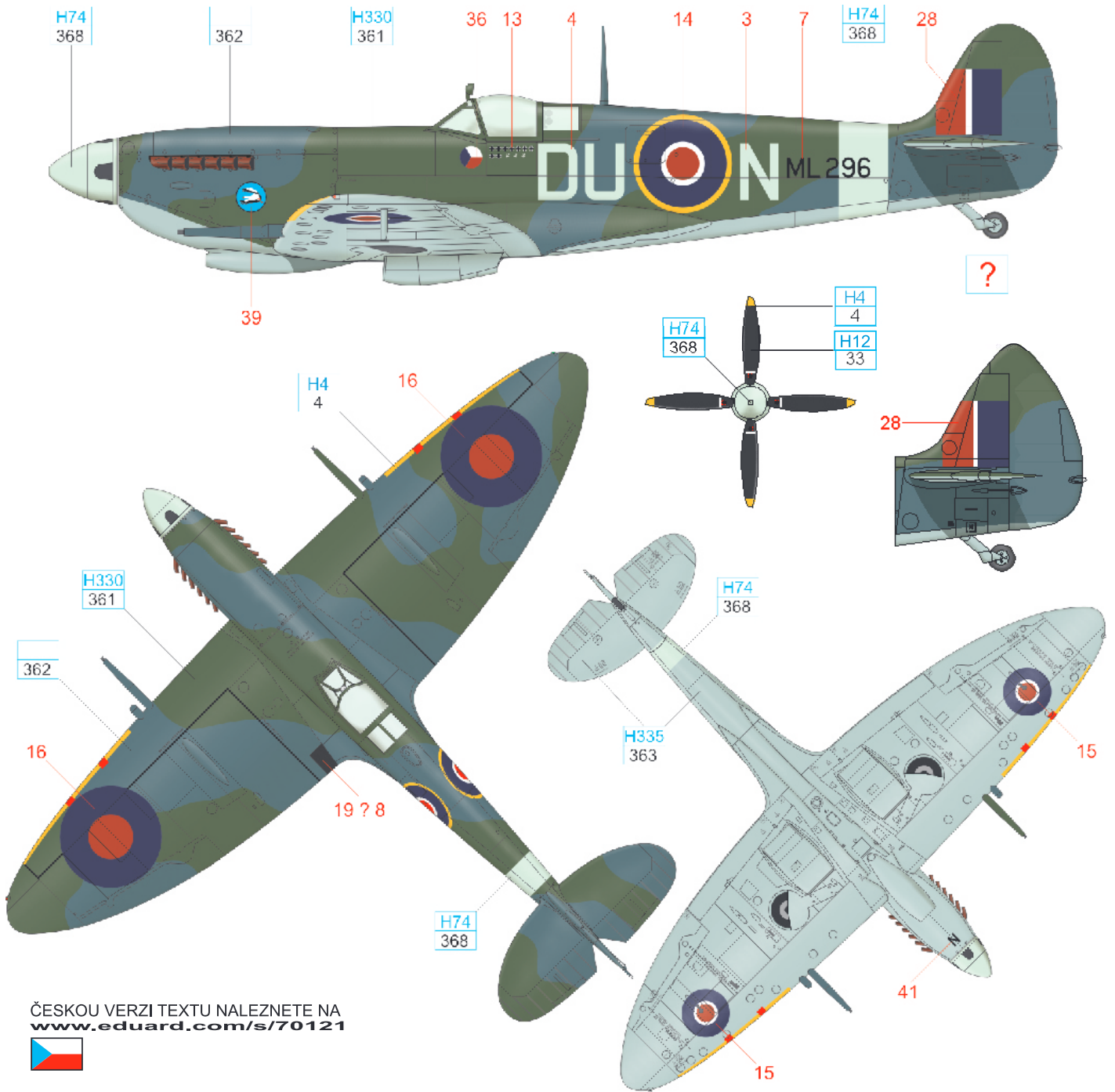

ČESKOU VERZI TEXTU NALEZNETE NA www.eduard.com/s/70121

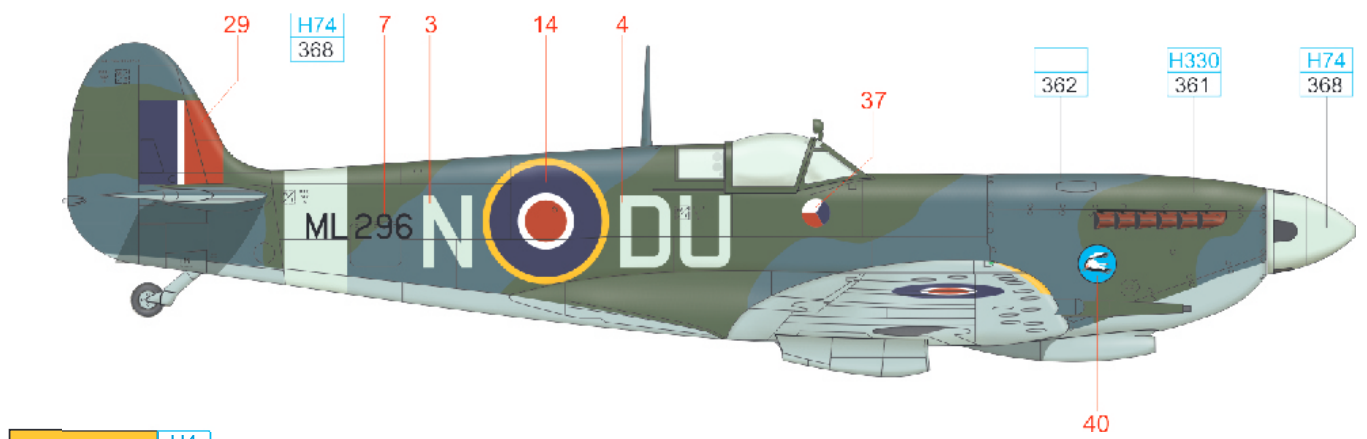

| | | | | | | | | | |
|--------|------------|-----------------|-------------|------------|-----|------------|-------------|-------|-----------|
| YELLOW | H4 4 | | | | | | | | |
| SKY | H74 368 | MEDIUM SEA GRAY | H335 363 | OCEAN GRAY | 362 | DARK GREEN | H330 361 | BLACK | H12 33 |



C Spitfire LF Mk.IXc, MH712, flown by W/O Henryk Dygala, No. 302 Squadron, Summer / Autumn 1944

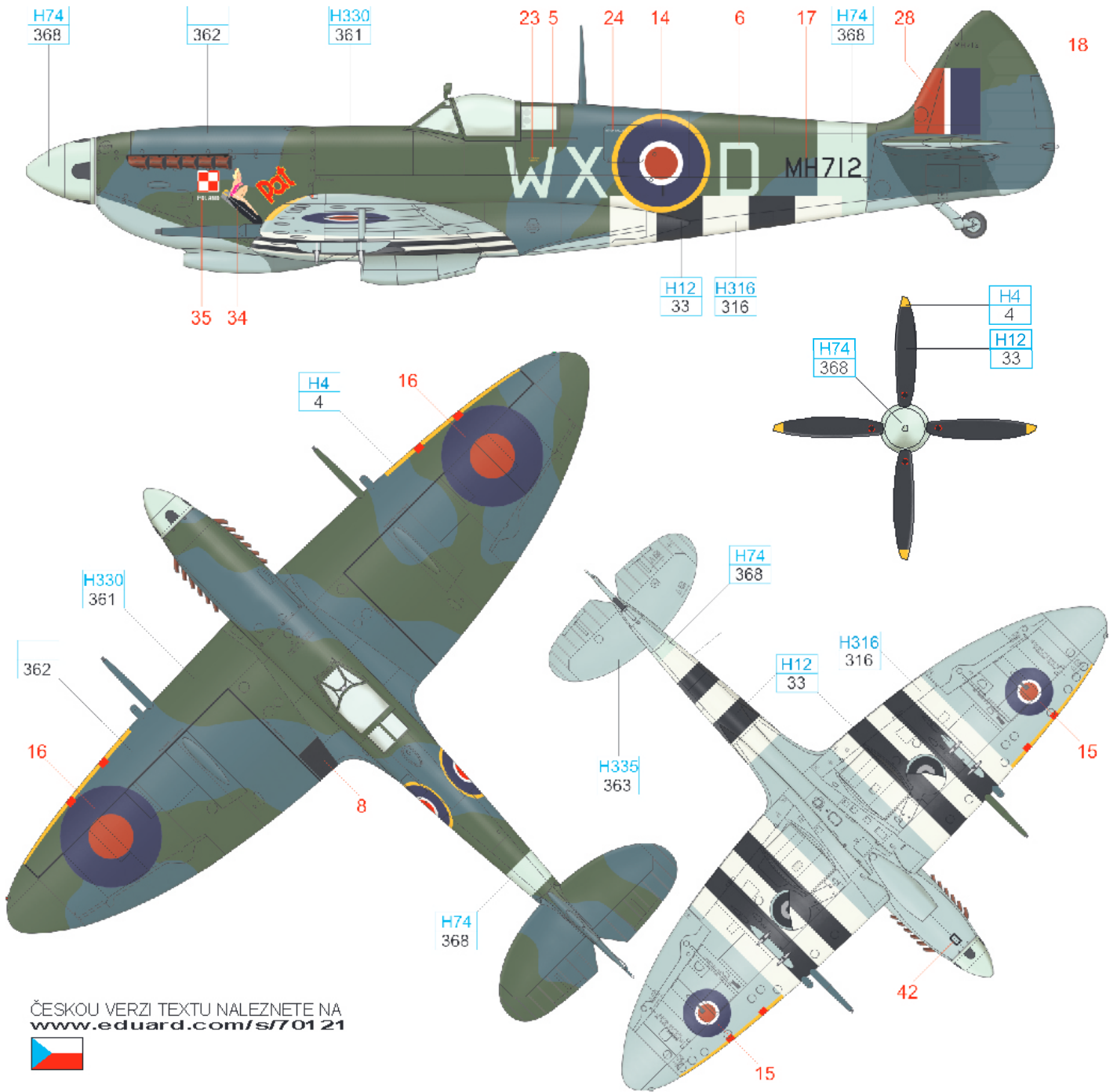

ČESKOU VERZI TEXTU NALEZNETE NA
www.eduard.com/s/70121

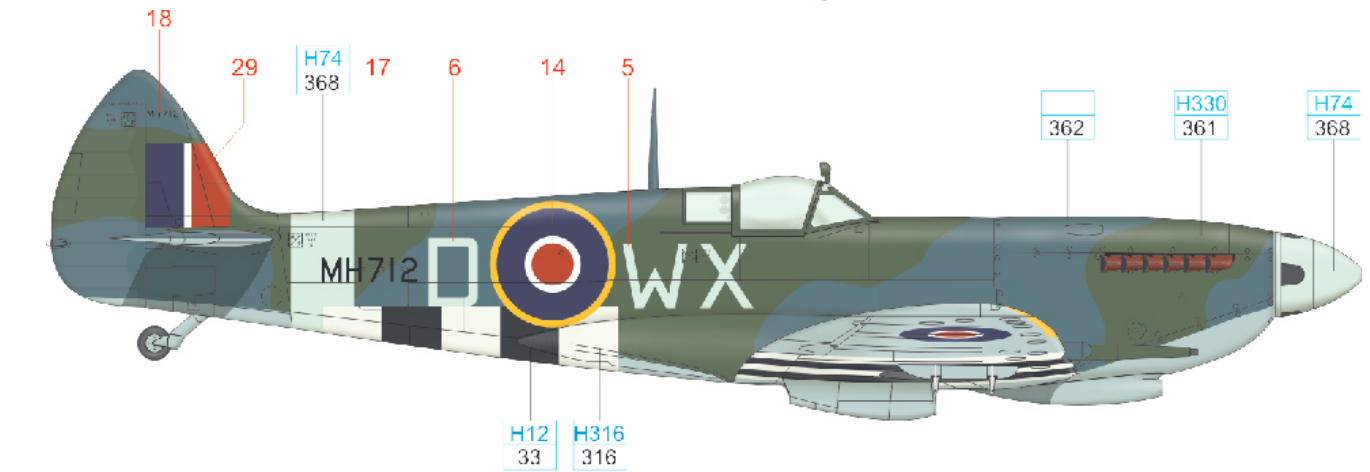

| | | | |
|------------|-------------|-----------------|-------------|
| WHITE | H316 316 | YELLOW | H4 4 |
| SKY | H74 368 | MEDIUM SEA GRAY | H335 363 |
| OCEAN GRAY | 362 | DARK GREEN | H330 361 |
| BLACK | H12 33 | | |



D Spitfire LF Mk.IXc, MJ250, No. 601 Squadron, Italy, Summer 1944

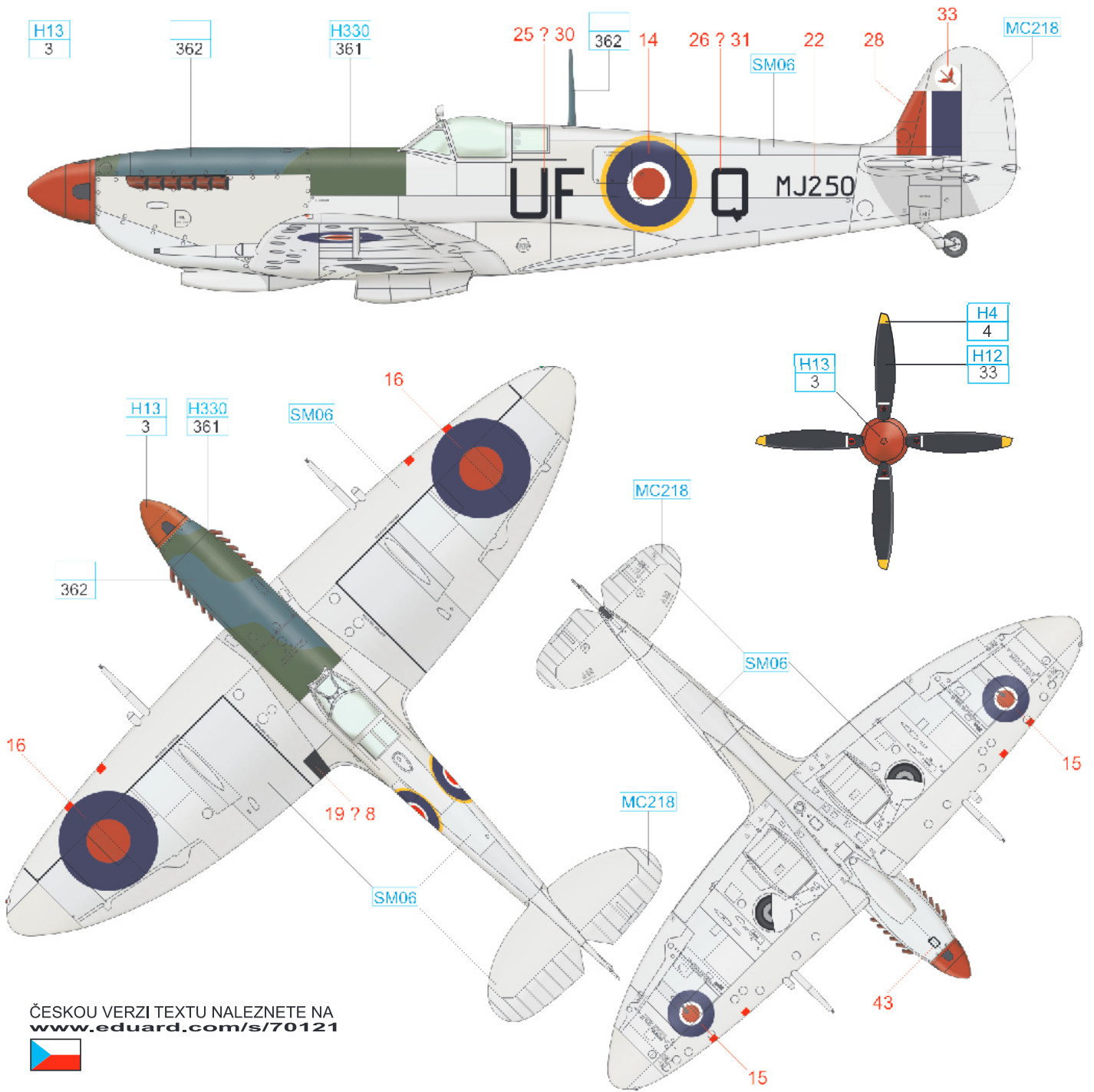

ČESKOU VERZI TEXTU NALEZNETE NA
www.eduard.com/s/70121

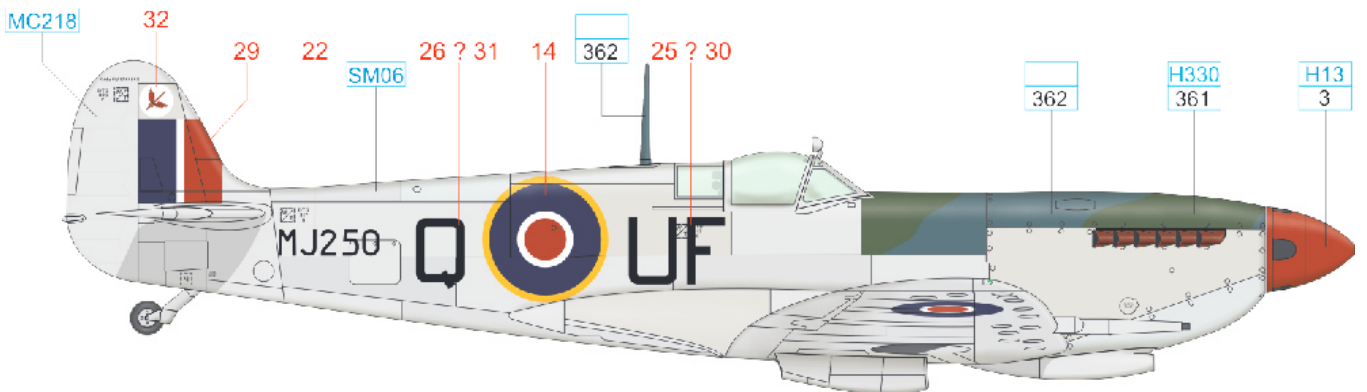

| | | | |
|---------------|-----------|------------|-------------|
| RED | H13 3 | YELLOW | H4 4 |
| CHROME SILVER | SM06 | ALUMINIUM | MC218 |
| OCEAN GRAY | 362 | DARK GREEN | H330 361 |
| BLACK | H12 33 | | |

E Spitfire LF Mk.IXc, ML135, flown by Jerry Billing, No. 401 Squadron, Tangmere AB, June 7 1944

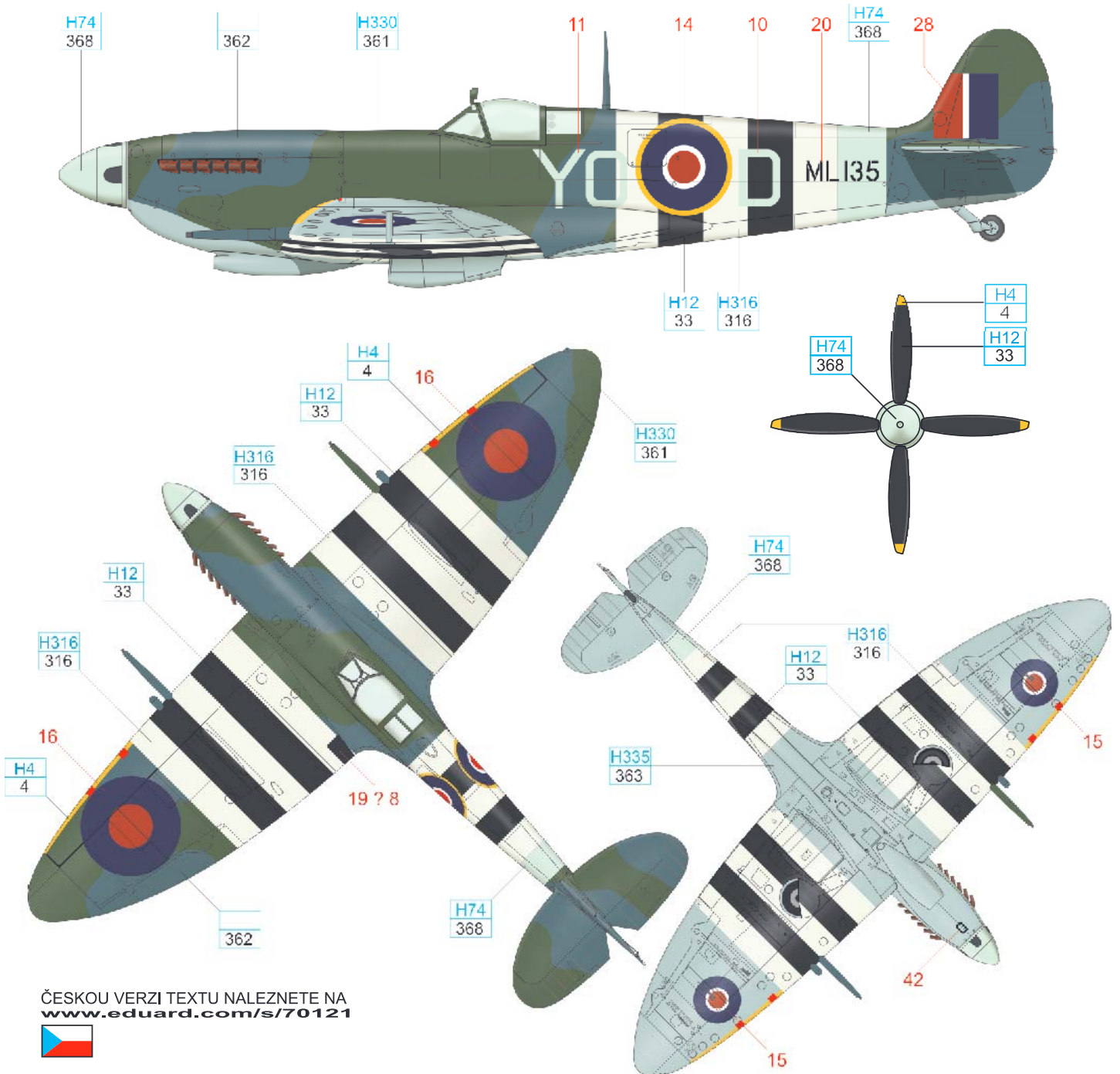

ČESKOU VERZI TEXTU NALEZNETE NA
www.eduard.com/s/70121

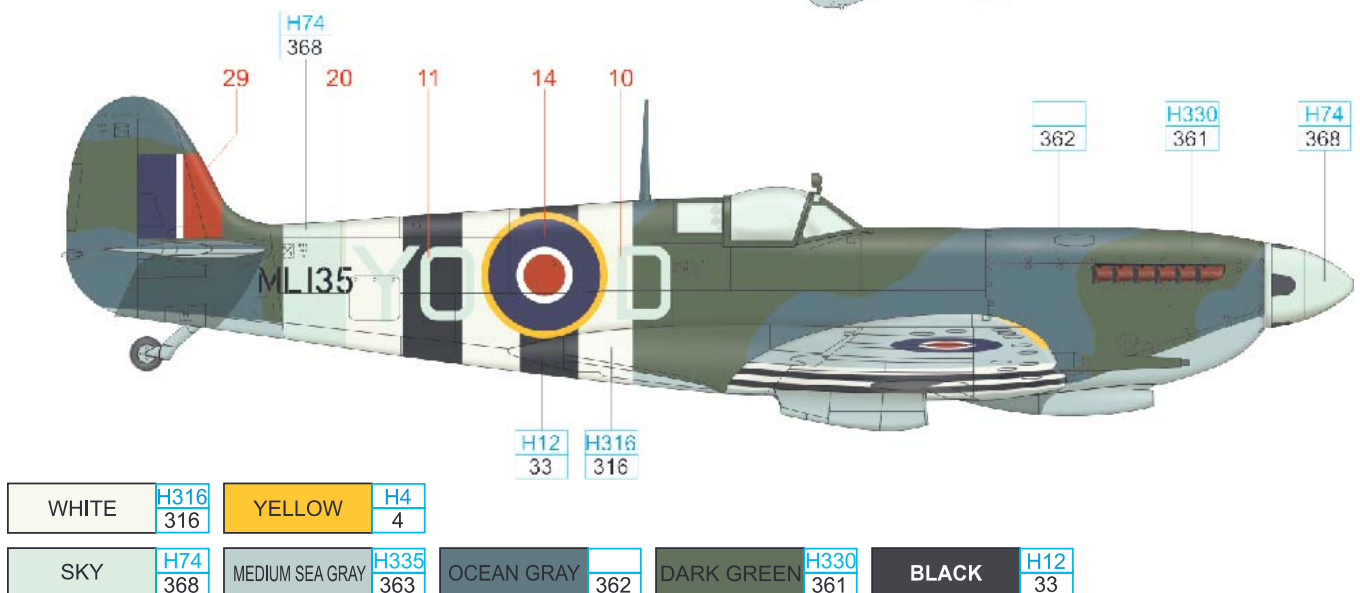

F Spitfire LF Mk.IXc, ML135, flown by Jerry Billing, No. 401 Squadron, France, July 1 1944

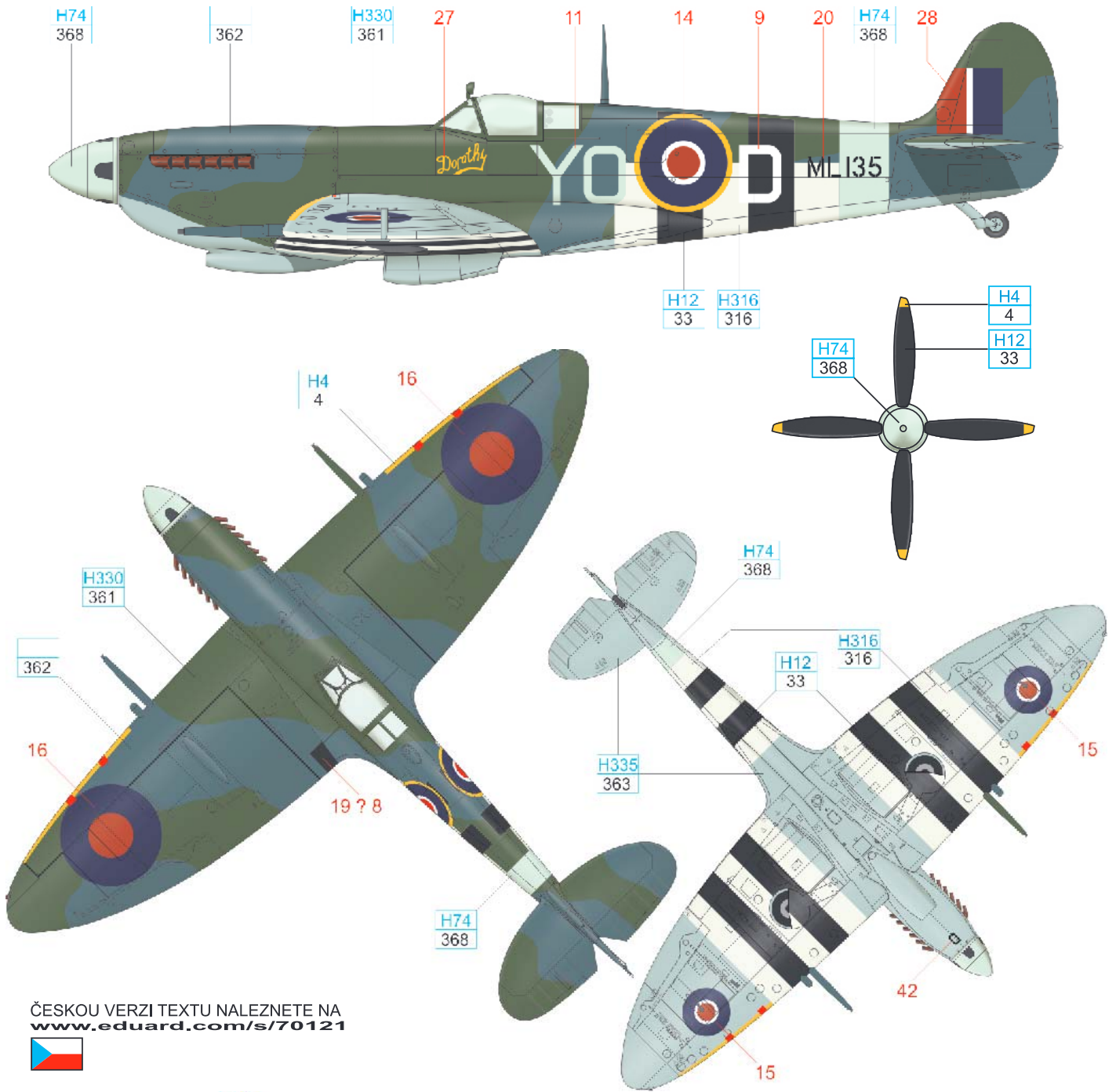

ČESKOU VERZI TEXTU NALEZNETE NA
www.eduard.com/s/70121

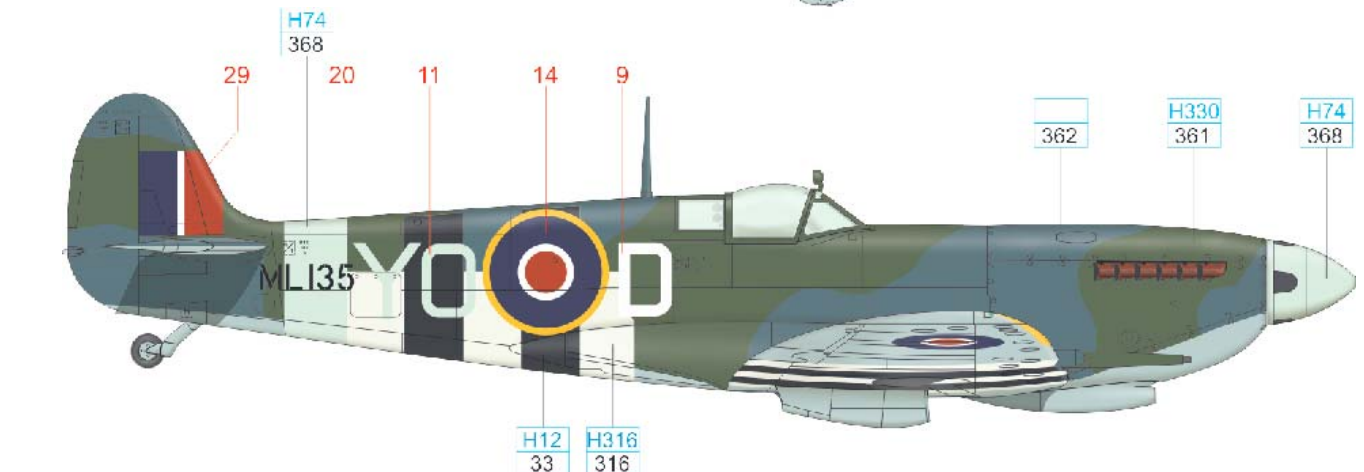

| | | | |
|-------|-------------|--------|---------|
| WHITE | H316 316 | YELLOW | H4 4 |
|-------|-------------|--------|---------|

| | | | | | | | | | |
|-----|------------|-----------------|-------------|------------|-----|------------|-------------|-------|-----------|
| SKY | H74 368 | MEDIUM SEA GRAY | H335 363 | OCEAN GRAY | 362 | DARK GREEN | H330 361 | BLACK | H12 33 |
|-----|------------|-----------------|-------------|------------|-----|------------|-------------|-------|-----------|

Spitfire Mk.IXc late version

STENCILING POSITIONS

